

AGA KHAN UNIVERSITY EXAMINATION BOARD
SECONDARY SCHOOL CERTIFICATE
COMPOSITE EXAMINATION 2008

Physics Paper II

Time allowed: 2 hours 20 minutes Marks 55

INSTRUCTIONS

Please read the following instructions carefully.

1. Check your name and school information. Sign that it is correct.

I agree that this is my name and school.
Candidate's signature

2. Write the number of the seat in which you are sitting.
3. RUBRIC. There are TEN questions. Answer ALL TEN questions. Questions 8, 9 and 10 each offer two choices. Attempt any one out of the TWO options in each.
4. When answering the questions:

Read each question carefully.
Use ONLY black ink.
Do not use staples, paper clips, glue or correcting fluid.
DO NOT write outside the answer box.
Complete your answer in the allocated space only.
5. The marks for the questions are shown in brackets ().
6. You may use a simple calculator without alpha numeric capability.

Q.1. (Total 6 Marks)

a.

Time in seconds	0.00	2.00	4.00	6.00
Speed in ms^{-1}	0.00	0.80	1.60	2.40

Teachers investigating motion down an inclined plane measure the speed of an iron ball at two seconds intervals after the ball starts to roll from rest down the plane:

i. Calculate the average acceleration over the first 6.00 seconds (2 Marks)

ii. How do the numbers in the table show that the acceleration was constant? (1 Mark)

b. Explain why it is dangerous to jump from a fast moving bus. (1 Mark)

c. Give any four examples each of scalar and vector quantities. (2 Marks)

S#	Examples of Scalar quantities	Examples of Vector quantities

Q.2.

(Total 6 Marks)

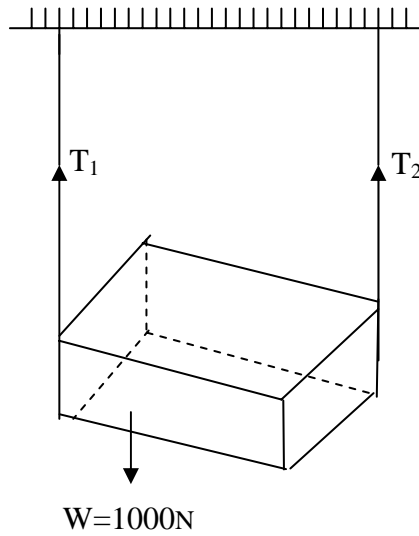

- a. Calculate the tension in each rope in the above figure, when the weight of the box is 1000 N. (2 Marks)

- b. State any TWO differences between g and G . (2 Marks)

S#	g	G

- c. State Boyle's and Charles' Laws. (2 Marks)

PLEASE TURN OVER THE PAGE

Q.3. (Total 3 Marks)

a. If the value of 'g' on earth is 9.8 ms^{-2} then what will be the value of 'g' on the moon? (1 Mark)

b. If sound waves are longitudinal why do we see transverse waves on the screen of the oscilloscope when we whistle into the microphone? (1 Mark)

c. Write any ONE difference between alternating and direct current (1 Mark)

Q.4.

(Total 6 Marks)

a. Name and define two types of reflection.

(2 Marks)

b. Write any TWO differences between primary and secondary rainbows.

(2 Marks)

S#	Primary Rainbow	Secondary Rainbow

c. Two convex lenses have focal lengths of 20 cm and 25 cm respectively. Calculate the power of the lenses and differentiate which lens has greater power.

(2 Marks)

PLEASE TURN OVER THE PAGE

Q.5. (Total 6 Marks)

a. For investigation and research we apply the scientific method. What is the first step in research? Define the research method. (2 Marks)

b. The mass of a metallic bob which we use in an experiment is 19.5 g and its volume after using a screw gauge is 3.91 cm^3 . Find its density. (2 Marks)

Answer

c. Define the term Joule from the given diagram. (2 Marks)

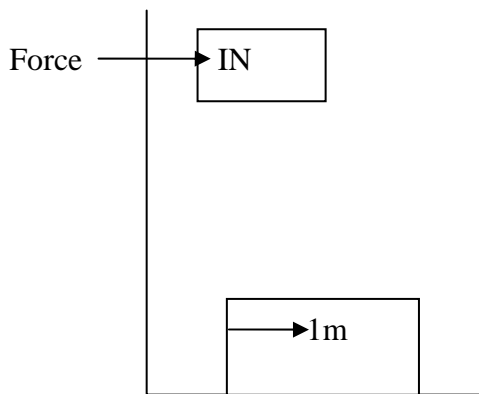

Q.6.

(Total 6 Marks)

a. What is a lever?

(1 Mark)

b.

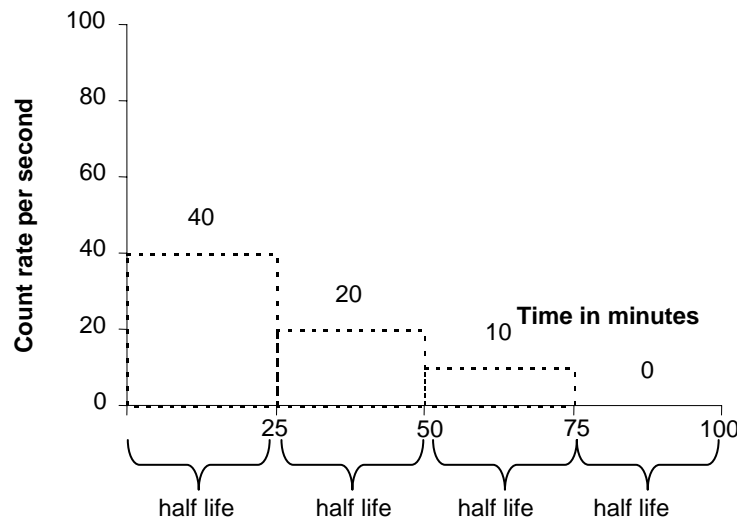

The above graph shows the count rate changes in Iodine – 128 with time. In the beginning it was 80 counts per seconds. (2 Marks)

i. What will be its counts per second after 100 minutes? _____

ii. What is its half life? _____

c. What do you understand by P-N junction diode and how does it convert as a rectifier? (2 Marks)

d. Why are fax machines much better than telex machines?

(1 Mark)

PLEASE TURN OVER THE PAGE

Q.7.

(Total 7 Marks)

a. The diagram below represents the arrangement of the particles in a solid.

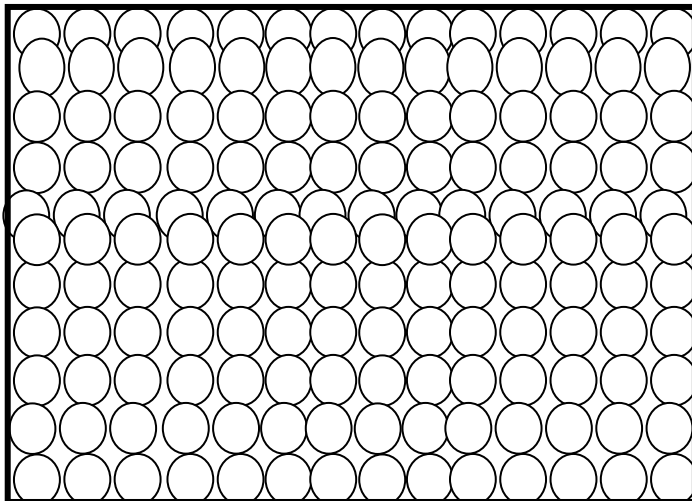

i. Describe the movement of the particles in the solid. (1 Mark)

ii. How does this movement change as the temperature of the solid is increased? (1 Mark)

b. Equal masses of steam and of water contain the same number of molecules. Explain why the volume of the steam is much greater than that of the water. (1 Mark)

c.

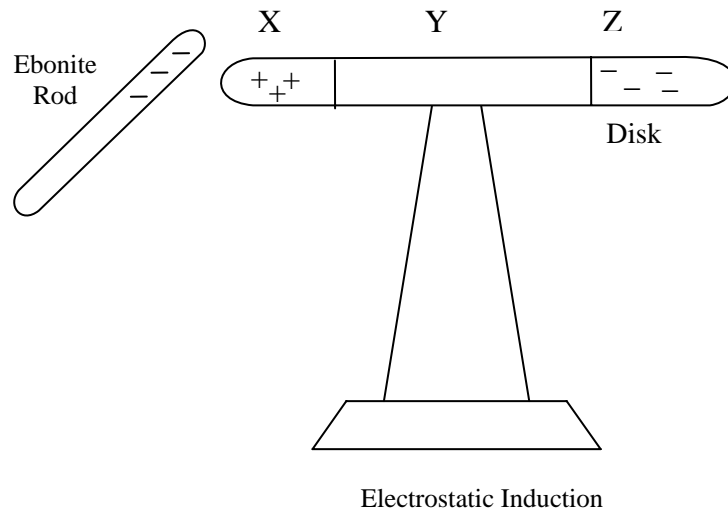

In the above diagram, why is there no charge in region Y?

(2 Marks)

d. Write down any TWO differences between an Ammeter and a Voltmeter.

(2 Marks)

S.#	Voltmeter	Ammeter

PLEASE TURN OVER THE PAGE

Q.9

(Total 5 Marks)

EITHER

- a. Describe the five differences between transverse and longitudinal waves.

OR

- b. How will you deduce Joules' Law? Prove $W = I^2Rt$.

Q.10.

(Total 5 Marks)

EITHER

a. State five properties of alpha rays.

OR

b. Draw the truth tables for NOT, OR, AND, NOR and NAND gates.

END OF PAPER

AGA KHAN UNIVERSITY EXAMINATION BOARD

SECONDARY SCHOOL CERTIFICATE

CLASS IX EXAMINATION 2009

Physics Paper II

Time allowed: 2 hours 25 minutes Marks 40

INSTRUCTIONS

Please read the following instructions carefully.

1. Check your name and school information. Sign that it is correct.

**I agree that this is my name and school.
Candidate's signature**

2. RUBRIC. There are EIGHT questions. Answer ALL EIGHT questions. Questions 6, 7 & 8 each offer TWO choices. Attempt any ONE choice from each.
3. When answering the questions:

Read each question carefully.
Use a black pencil for diagrams. DO NOT use coloured pencils.
DO NOT use staples, paper clips, glue, correcting fluid or ink erasers.
Complete your answer in the allocated space only. DO NOT write outside the answer box.
4. The marks for the questions are shown in brackets ().

Q.1. (Total 4 Marks)

a. Careful observation is the first step in study of scientific problems. Discuss. (2 Marks)

b.

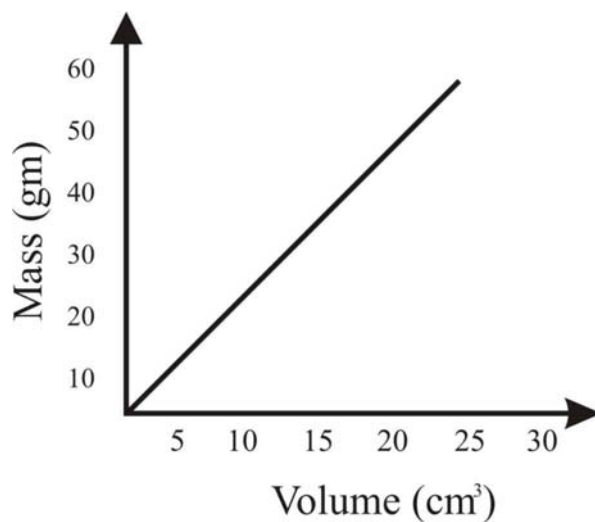

Consider the graph between volume and mass.

i. Which physical quantity is defined by the gradient of the graph? (1 Mark)

ii. Calculate the mass of a body having 25cm^3 of volume. (1 Mark)

Q.2.

(Total 6 Marks)

- a. It has been observed that a driver increases the velocity of his car on approaching a hilly road. Why? (1 Mark)

b.

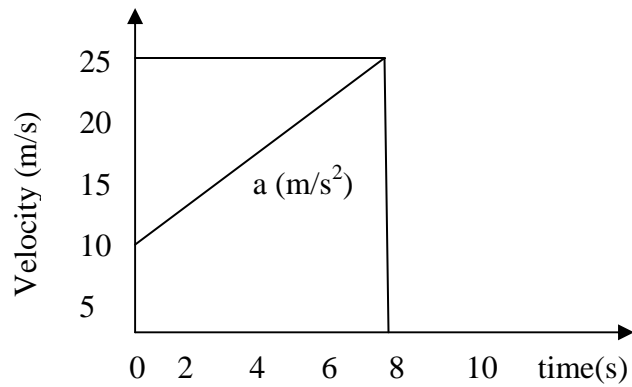

The above graph is representing the motion of a motor cycle. Calculate the acceleration produced by the motor cycle and also find out the distance covered by it after 8 seconds? (5 Marks)

PLEASE TURN OVER THE PAGE

Q.3. (Total 4 Marks)

a. What is equilibrium? (1 Mark)

b. Describe the states of equilibrium. (3 Marks)

Q.4. (Total 4 Marks)

a. A body is thrown vertically upwards; its velocity goes on decreasing. What will happen to its K.E as its velocity becomes zero? (1 Mark)

b. How can a small effort be used to convert a large load with the help of a machine? (1 Marks)

c. Define the following terms: (2 Marks)

- i. Efficiency
- ii. Mechanical advantage

Q.5.

(Total 7 Marks)

a. Define boiling point.

(1 Mark)

b. Give TWO differences between evaporation and boiling.

(2 Marks)

c. Gas particles in a container exert pressure on the walls of the container

i. What is the main cause of the pressure?

(1 Mark)

ii. What will be the effect if more gas is added?

(1 Mark)

d. Why does tea in a cup cool faster than tea in a tea pot?

(1 Marks)



e. Why are burns caused by steam more severe than burns caused by boiling water?

(1 Marks)

PLEASE TURN OVER THE PAGE

AGA KHAN UNIVERSITY EXAMINATION BOARD

SECONDARY SCHOOL CERTIFICATE

CLASS IX EXAMINATION 2010

Physics Paper II

Time allowed: 2 hours 25 minutes Marks 40

INSTRUCTIONS

Please read the following instructions carefully.

1. Check your name and school information. Sign that it is correct.

**I agree that this is my name and school.
Candidate's signature**

2. RUBRIC. There are NINE questions. Answer ALL NINE questions. Questions 7, 8 & 9 each offer TWO choices. Attempt any ONE choice from each.
3. When answering the questions:

Read each question carefully.
Use a black pencil for diagrams. DO NOT use coloured pencils.
DO NOT use staples, paper clips, glue, correcting fluid or ink erasers.
Complete your answer in the allocated space only. DO NOT write outside the answer box.
4. The marks for the questions are shown in brackets ().
5. You may use a simple calculator if you wish.

Q.1.

(Total 3 Marks)

Write THREE differences between Base and Derived physical quantities.

S. No.	Base quantities	Derived quantities
1.		
2.		
3.		

Q.2.

(Total 6 Marks)

Given below is the speed-time graph for a motorcycle travelling along a straight road.

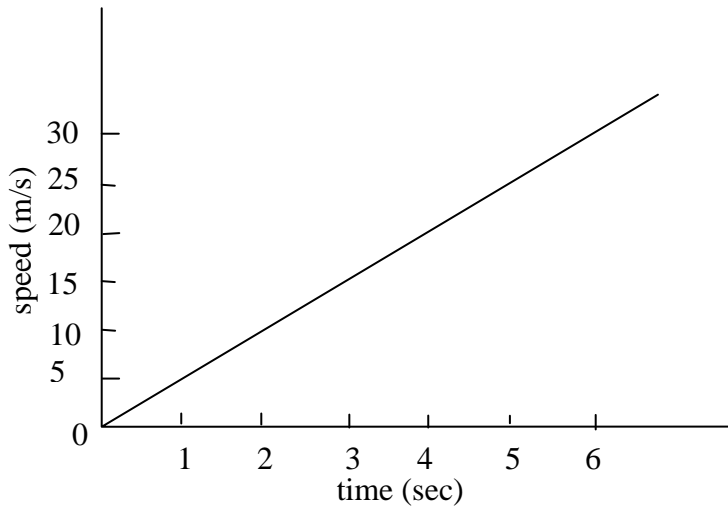

Time in sec	0	1	2	3	4	5	6
Speed in m/s	0	5	10	15	20	25	30

a. What is the distance travelled by the motorcycle in 6 seconds? (2 Marks)

b. What is the acceleration of the motorcycle? (2 Marks)

c. What does the gradient of speed-time graph show? (1 Mark)

d. What does the area under the line of speed-time graph show? (1 Mark)

PLEASE TURN OVER THE PAGE

Q.3. (Total 3 Marks)

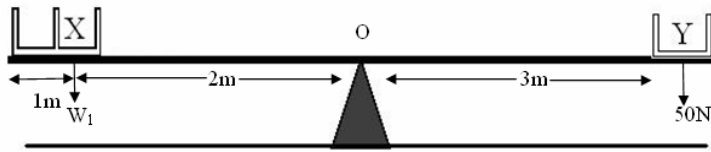

The above figure shows a balanced see-saw where a student is seated at position X, while his friend is seated at position Y.

a. State the principle of moment. (1 Mark)

b. What will be the weight of the student? (2 Marks)

Q.4.

(Total 3 Marks)

If the Earth pulls an object of mass 100 gm with a force of 1 N, then the same object on the Moon will have less weight of about $\frac{1}{6}$ N.

a. What will be the weight of that object on the Moon?

(2 Marks)

b. Why is the weight of that object on the Moon less than on the Earth?

(1 Mark)

PLEASE TURN OVER THE PAGE

Q.6.

(Total 4 Marks)

A vacuum flask is made of two glass walls with a near-vacuum in between. The bottle is used to maintain liquids, and sometimes solids, at near-constant temperatures. An efficient flask can keep its contents at the desired hot or cold temperature for as long as three days. This is achieved by preventing the transfer of heat between the bottle and its surroundings. The walls are usually made of glass and painted with a reflective metal to reduce the transfer of heat by radiation. The vacuum in the walls greatly reduces the transfer of heat by convection.

a. Write any ONE way to stop heat transfer by convection in the vacuum flask. (1 Mark)

b. Why are the walls of the flask painted with reflecting materials? (1 Mark)

c. Identify any ONE negative effect, if the walls of the flask are made of copper. (1 Mark)

d. How is radiation different from conduction and convection? (1 Mark)

Q.8.

(Total 5 Marks)

EITHER

- a. A lift of mass 600 kg carries a load of 90 kg at a height of 15 m in 10 sec. Calculate the work done in lifting the load and the power of the motor driving the lift.

OR

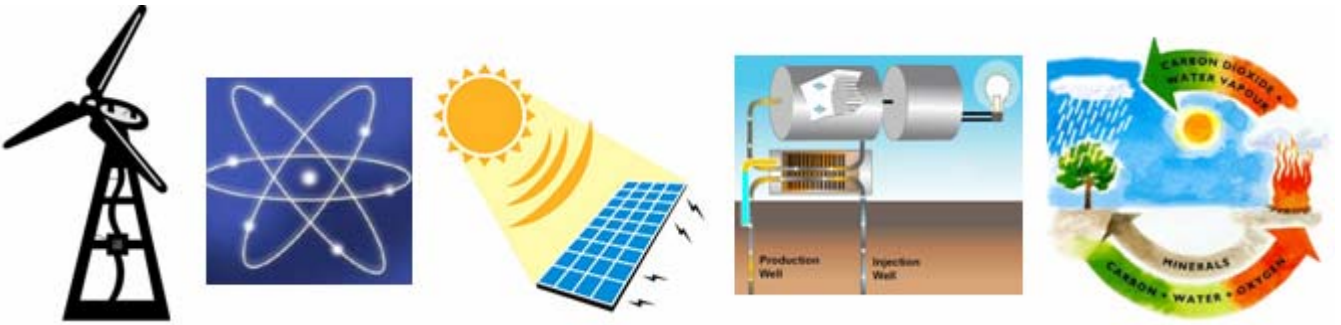

- b. Recognize the above renewable energy sources and describe any TWO of them.

PLEASE TURN OVER THE PAGE

Q.9.

(Total 5 Marks)

EITHER

- a. Liquid left in air with no rise in temperature slowly changes into vapours. This process is known as evaporation.

Identify and describe any TWO factors affecting the rate of evaporation.

OR

- b. In the given diagram, an electric lamp is placed directly above a paper board, on which a piece of paper is pinned along its top edge.

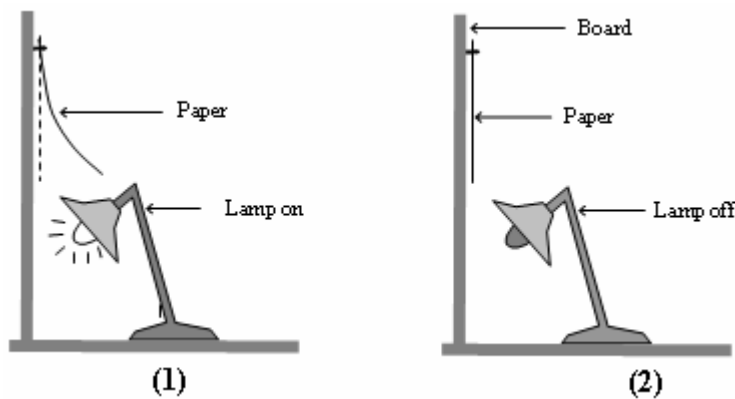

Explain what happens when the lamp is switched on and off.

AGA KHAN UNIVERSITY EXAMINATION BOARD

SECONDARY SCHOOL CERTIFICATE

CLASS IX EXAMINATION

MAY 2011

Physics Paper II

Time allowed: 2 hours 25 minutes Marks 40

INSTRUCTIONS

Please read the following instructions carefully.

1. Check your name and school information. Sign that it is correct.

**I agree that this is my name and school.
Candidate's signature**

2. RUBRIC. There are NINE questions. Answer ALL NINE questions. Questions 7, 8 & 9 each offer TWO choices. Attempt any ONE choice from each.
3. When answering the questions:

Read each question carefully.
Use a black pencil for diagrams. DO NOT use coloured pencils.
DO NOT use staples, paper clips, glue, correcting fluid or ink erasers.
Complete your answer in the allocated space only. DO NOT write outside the answer box.
4. The marks for the questions are shown in brackets ().
5. You may use a simple calculator if you wish.

Q.1. (Total 3 Marks)

Complete the given table of quantities.

Fundamental and derived units

Quantity	Formula	SI unit	Measuring Instrument
		Ampere	
			Spring balance
Heat			

Q.2. (Total 6 Marks)

a. What are the TWO different ways of deriving the formula of Newton's second law of motion? Prove their equivalence. (3 Marks)

b. Calculate the force that must be applied in the given diagram.

(3 Marks)

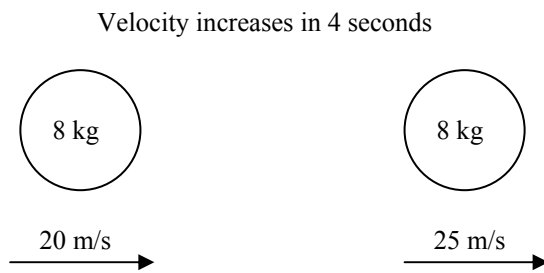

Q.3.

(Total 3 Marks)

State the principle of moments and find the magnitude of F_3 in the given diagram.

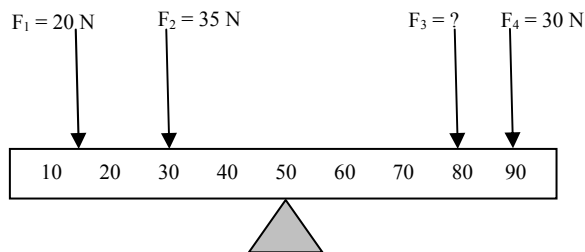

PLEASE TURN OVER THE PAGE

Q.4. (Total 3 Marks)

The given diagram shows two identical satellites *A* and *B* orbiting the earth.

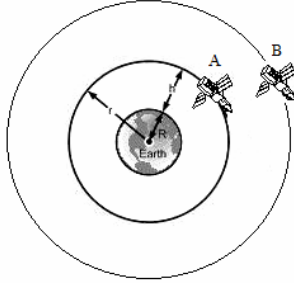

a. Which one of the satellites is attracted more strongly by the earth? (1 Mark)

b. Which of the satellites is revolving with a slower speed and why? (2 Marks)

Q.5.

(Total 6 Marks)

a. In the given diagram, one form of energy is converted into the other form using given hints between the blocks. Fill the blocks with correct form of energy. (4 Marks)

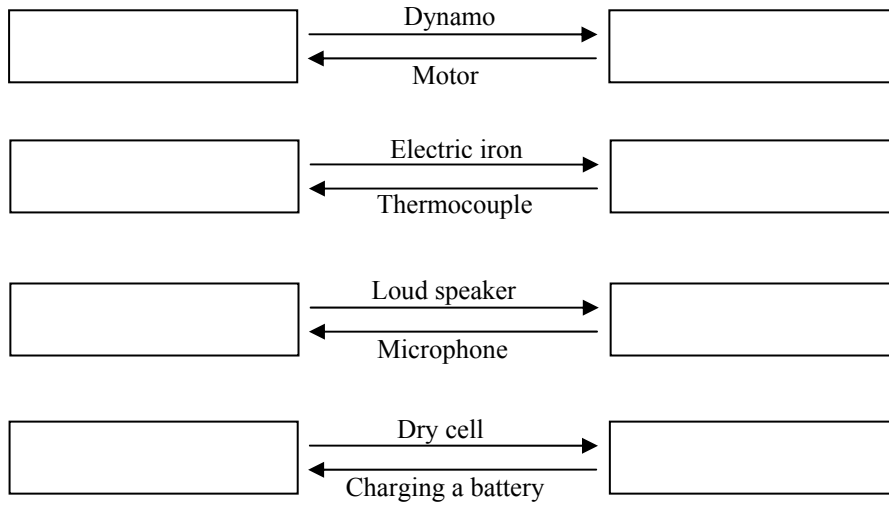

b. Define any TWO forms of energy.

(2 Marks)

Q.6. (Total 4 Marks)

Temperatures of three different cities in summer are given. Which one of the cities will be facing more heat? Show the calculation.

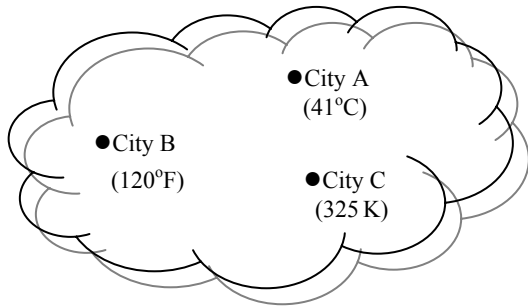

City A	City B	City C

Q.8. (Total 5 Marks)

EITHER

a. A locomotive is pulling a train from one station and travels along a straight horizontal track towards another station. Its speed at regular interval of time is recorded in the given table.

Velocity	0	30	40	40	40	40	0
Time	0	1	2	4	6	8	12

Draw and describe the graph of the whole journey in terms of uniform velocity, acceleration, and retardation.

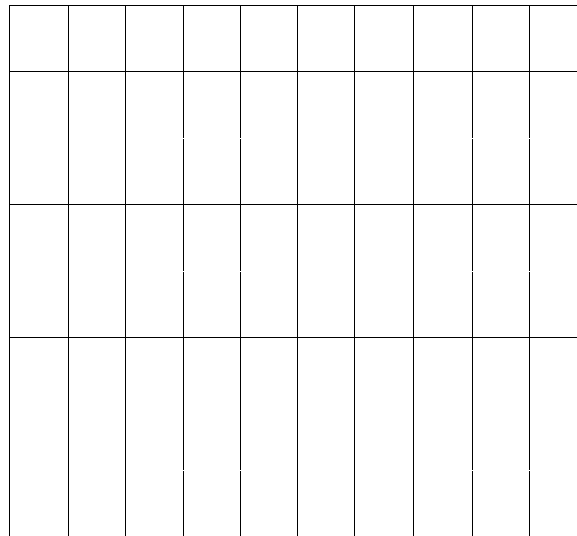

Q.9. (Total 5 Marks)

EITHER

a. Define evaporation. Explain the activity mentioned in the given diagram and prove that evaporation is a cooling process.

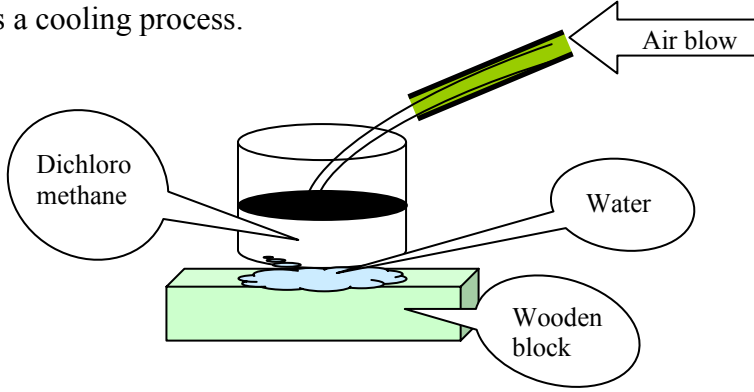

OR

b. State any FIVE examples of heat transfer by the process of convection in everyday life.

AGA KHAN UNIVERSITY EXAMINATION BOARD

SECONDARY SCHOOL CERTIFICATE

CLASS IX EXAMINATION

MAY 2012

Physics Paper II

Time allowed: 2 hours 25 minutes Marks 40

INSTRUCTIONS

Please read the following instructions carefully.

1. Check your name and school information. Sign that it is correct.

**I agree that this is my name and school.
Candidate's signature**

2. RUBRIC. There are NINE questions. Answer ALL NINE questions. Questions 7, 8 & 9 each offer TWO choices. Attempt any ONE choice from each.
3. When answering the questions:

Read each question carefully.
Use a black pencil for diagrams. DO NOT use coloured pencils.
DO NOT use staples, paper clips, glue, correcting fluid or ink erasers.
Complete your answer in the allocated space only. DO NOT write outside the answer box.
4. The marks for the questions are shown in brackets ().
5. You may use a simple calculator if you wish.

Q.1. (Total 3 Marks)

Complete the given table.

Physical Quantity	S.I. Unit	Symbol
Mass		
Electric current		
Luminous intensity		

Q.2. (Total 6 Marks)

The velocity time graph represents the motion of the cyclist travelling on a straight levelled road.

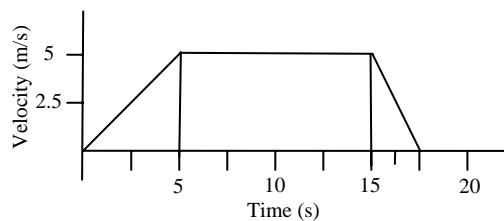

i. What will the velocity of the cyclist be after 5 seconds?

ii. During which interval of time will the cyclist have no acceleration?

iii. How much distance (d) is covered during 5 to 15 seconds?

iv. Find the deceleration.

Q.3.

(Total 3 Marks)

A uniform rod is balanced with a mass of 2 kg on its left end.

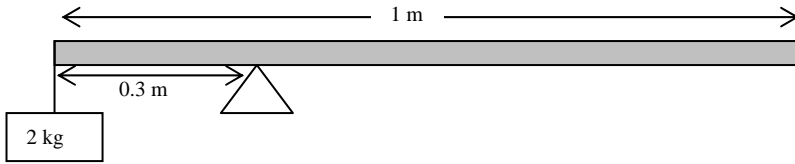

Using the information given in the diagram, calculate weight of the rod. (Take $g = 10 \text{ m/s}^2$)

Q.4.

(Total 3 Marks)

The pull of gravity is one of the important forces present on earth.

State any THREE important facts which explain the importance of pull of gravity on earth.

PLEASE TURN OVER THE PAGE

Q.5. (Total 6 Marks)

a. Differentiate between renewable and non-renewable energy sources. (2 Marks)

	Renewable energy sources	Non-renewable energy sources
1		
2		

b. Give any TWO examples each of renewable and non-renewable energy sources. (4 Marks)

S.No.	Examples of renewable energy sources	Examples of non-renewable energy sources
1		
2		

Q.6.

(Total 4 Marks)

Describe the processes mentioned in the given diagram.

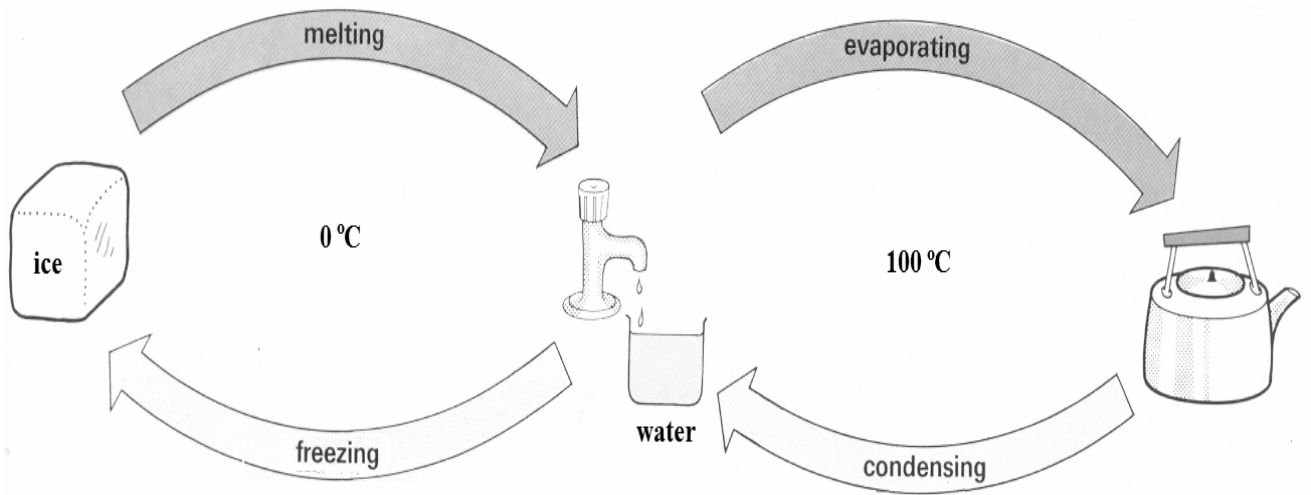

PLEASE TURN OVER THE PAGE

Q.8.

(Total 5 Marks)

EITHER

a. Under what conditions is the work done called positive, negative and zero work?

Give ONE example each of positive and negative work.

OR

b. Define the following terms:

- i. Stress
- ii. Tensile strain
- iii. Young's modulus

Also write the formulae for stress and tensile strain.

PLEASE TURN OVER THE PAGE

AGA KHAN UNIVERSITY EXAMINATION BOARD

SECONDARY SCHOOL CERTIFICATE

CLASS IX EXAMINATION

MAY 2013

Physics Paper II

Time: 2 hours 25 minutes Marks: 40

INSTRUCTIONS

Please read the following instructions carefully.

1. Check your name and school information. Sign if it is accurate.

**I agree that this is my name and school.
Candidate's signature**

2. RUBRIC. There are NINE questions. Answer ALL questions. Questions 7, 8 & 9 each offer TWO choices. Attempt any ONE choice from each.
3. When answering the questions:

Read each question carefully.
Use a black pencil for diagrams. DO NOT use coloured pencils.
DO NOT use staples, paper clips, glue, correcting fluid or ink erasers.
Complete your answer in the allocated space only. DO NOT write outside the answer box.
4. The marks for the questions are shown in brackets ().
5. You may use a simple calculator if you wish.

Q.1.

(Total 3 Marks)

“Physics helps in attaining sustainable development of our society.” Discuss the given statement by mentioning **THREE** important roles of physics.

Q.2.

(Total 6 Marks)

a. Explain that motion and rest are relative terms.

(3 Marks)

b. Give any THREE examples to explain how a body can be at motion and in rest simultaneously.

(3 Marks)

PLEASE TURN OVER THE PAGE

Q.3.

(Total 3 Marks)

A metre rod is supported at its middle point O as shown in the given figure.

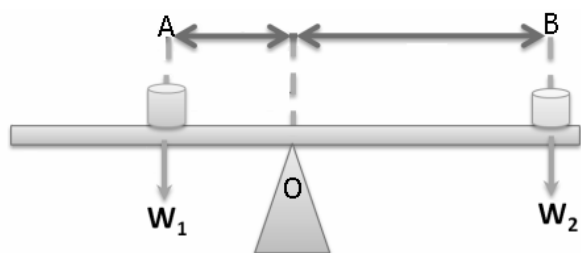

A block of weight 5 N is suspended at point B, 20 cm from O. Find the weight of the block that balances it at point A, 10 cm from O.

Q.4.

(Total 3 Marks)

Two marble balls of 36 kg and 20 kg are placed in such a way that the distance between their centres is 60 cm. Find the force of attraction between them.

(Take $G = 6.67 \times 10^{-11} \text{Nm}^2 / \text{kg}^2$).

PLEASE TURN OVER THE PAGE

Q.5. (Total 6 Marks)

a. The given diagram represents a steam-powered generator. Describe how energy is transformed from one form to another. (4 Marks)

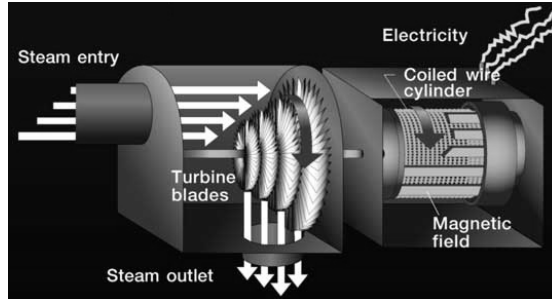

b. Write TWO drawbacks of this process of power generation associated with the environment. (2 Marks)

Q.6.

(Total 4 Marks)

A person is sitting in front of a room heater. Explain the possible ways through which heat is transferred to that person.

PLEASE TURN OVER THE PAGE

OR

b. The given figure shows the brake system of a vehicle.

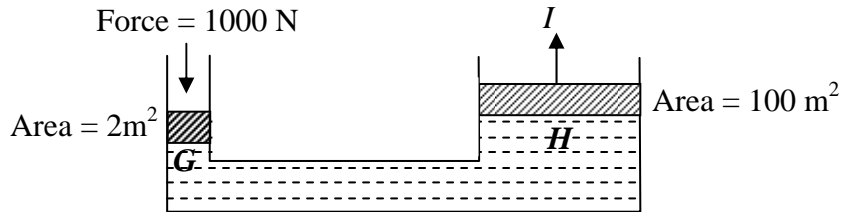

Name the law which is used in the above system. Calculate the pressure exerted by the liquid at G and H and the force which is applied at I .

PLEASE TURN OVER THE PAGE

Q.8. (Total 5 Marks)

EITHER

- a. A boy walks from 750 m North and then 500 m South-East at 40° to reach home.
Draw a vector diagram to determine the resultant displacement of the boy by using a suitable scale.

Calculate the velocity of the boy if he takes 5 minutes to reach home.

OR

- b. A force of 40 N is applied to a carton in rightward direction on a frictionless horizontal surface to produce an acceleration of 3 m/s^2 .

Show the direction of force and acceleration in the given diagram and calculate the mass of the block.



Q.9.

(Total 5 Marks)

EITHER

a. Describe any FIVE factors which affect surface evaporation.

OR

b. Describe any FIVE uses of good and bad conductors.

END OF PAPER

AGA KHAN UNIVERSITY EXAMINATION BOARD

SECONDARY SCHOOL CERTIFICATE

CLASS IX EXAMINATION

MAY 2014

Physics Paper II

Time: 2 hours 25 minutes Marks: 40

INSTRUCTIONS

Please read the following instructions carefully.

1. Check your name and school information. Sign if it is accurate.

**I agree that this is my name and school.
Candidate's signature**

2. RUBRIC. There are NINE questions. Answer ALL questions. Questions 7, 8 & 9 each offer TWO choices. Attempt any ONE choice from each.
3. When answering the questions:

Read each question carefully.
Use a black pencil for diagrams. DO NOT use coloured pencils.
DO NOT use staples, paper clips, glue, correcting fluid or ink erasers.
Complete your answer in the allocated space only. DO NOT write outside the answer box.
4. The marks for the questions are shown in brackets ().
5. You may use a simple calculator if you wish.

Q.1. (Total 3 Marks)

The given diagram shows the diameter of a copper wire measured by a screw gauge.

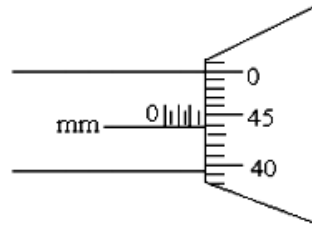

With the help of the reading shown in the diagram, calculate the diameter of the copper wire in scientific notation.

Q.2.

(Total 6 Marks)

a. A speed-time graph for a car travelling on a straight road is shown below.

(3 Marks)

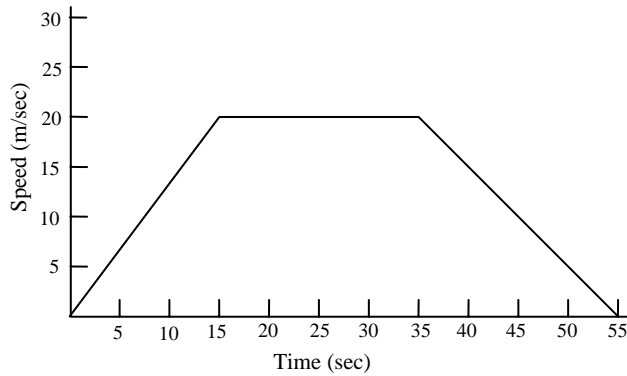

- i. What is the distance travelled during the first 15 sec?
- ii. What is the deceleration during the last 10 sec?
- iii. What is the average speed of the whole journey?

b. A paratrooper jumps from a helicopter. He does not open his parachute straight away.

The table shows his speed during the 10 seconds after his jump.

(3 Marks)

Time in sec	0	1	2	3	4	5	6	7	8	9	10
Speed in m/s	0	10	20	30	40	50	35	27	22	20	20

- i. After how many seconds does he open his parachute?

- ii. Name the force that pulls the paratrooper down.

- iii. Name the force that acts in an upward direction.

PLEASE TURN OVER THE PAGE

Q.3. (Total 3 Marks)

The diagram below shows a person who is about to open the door.

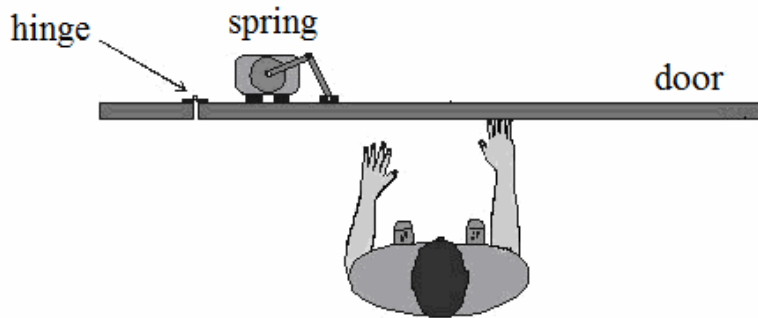

a. Suggest any TWO changes that the person can make in order to open the door more easily. (2 Marks)

b. At what angle does the turning effect have maximum value? (1 Mark)

Q.4. (Total 3 Marks)

Is Newton's law of gravitation consistent with Newton's third law of motion? Give any TWO conditions of the third law of motion.

Q.5.

(Total 6 Marks)

- a. In a hydroelectric power generation station, energy transformations take place. Describe the process of power generation by hydroelectric dam and conversion of different forms of energy into electrical energy. (3 Marks)

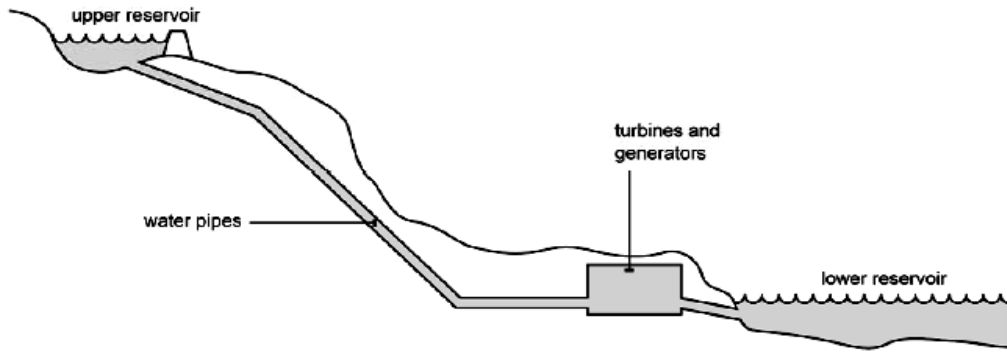

- b. State any THREE disadvantages of hydroelectric power generation. (3 Marks)

Q.6. (Total 4 Marks)

a. Why does evaporation of water cause cooling? (2 Marks)

b. Why are conduction and convection not involved in the transfer of heat from the sun to the earth? (2 Marks)

Q.8.

(Total 5 Marks)

EITHER

- a. Describe the process of power generation from fossil fuel input by drawing a block diagram of the process.

OR

- b. The pressure in a pressure cooker is raised by squeezing more gas into a limited space. Explain why gases exert greater pressure when they are squeezed into smaller space.

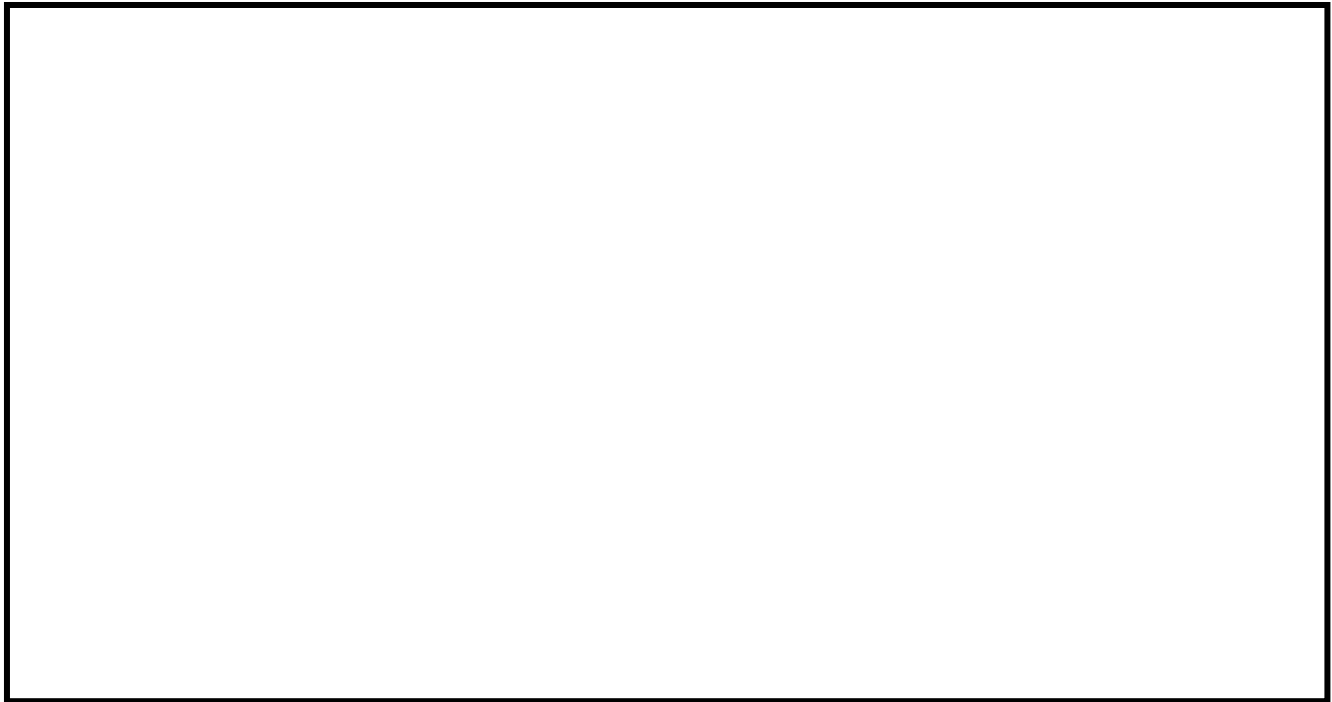

AGA KHAN UNIVERSITY EXAMINATION BOARD

SECONDARY SCHOOL CERTIFICATE

CLASS IX EXAMINATION

MAY 2015

Physics Paper II

Time: 2 hours 25 minutes Marks: 40

INSTRUCTIONS

Please read the following instructions carefully.

1. Check your name and school information. Sign if it is accurate.

**I agree that this is my name and school.
Candidate's signature**

2. RUBRIC. There are ELEVEN questions. Answer ALL questions. Questions 9, 10 & 11 each offer TWO choices. Attempt any ONE choice from each.
3. When answering the questions:

Read each question carefully.
Use a black pencil for diagrams. DO NOT use coloured pencils.
DO NOT use staples, paper clips, glue, correcting fluid or ink erasers.
Complete your answer in the allocated space only. DO NOT write outside the answer box.
4. The marks for the questions are shown in brackets ().
5. You may use a simple calculator if you wish.

Q.1. (Total 3 Marks)

‘Physics helps in the development of our society.’ In the light of the given statement mention any THREE important roles of physics giving a brief description of each.

Q.2.

(Total 3 Marks)

Give any ONE difference between each of the following pairs.

Distance	Displacement

Speed	Velocity

Scalar Quantities	Vector Quantities

Q.3. (Total 3 Marks)

In the given diagram, calculate the centripetal force acting on the bucket of water.

(Note: Extract data from the given diagram and provide your answer in SI unit.)

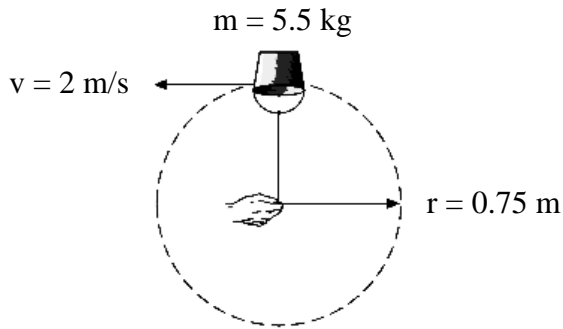

Q.4. (Total 3 Marks)

A body that remains at rest or moves uniformly even though a number of forces are acting on it is said to be in equilibrium. There are three states of equilibrium.

Write any ONE example of each state of equilibrium from daily life. For each example, make clear which state of equilibrium is involved.

Q.5.

(Total 3 Marks)

How does the gravitational force cause artificial satellites to orbit the Earth?

Q.6.

(Total 3 Marks)

An object falls from the height of 40 m. Calculate its velocity, when it strikes the ground where the value of 'g' = 9.8 m/s².

(Note: Extract data from the question and provide your answer in SI unit.)

Q.7. (Total 3 Marks)

Snowshoes are flat frames that could be attached to the bottom of shoes, so that a skier can walk on the deep snow without sinking.

Describe using THREE points how the snowshoes prevent a skier from sinking into the soft snow.



Snowshoe



Normal shoe

Q.8. (Total 4 Marks)

a. Identify the temperature scales of the following thermometers and write the scales in the boxes. (3 Marks)

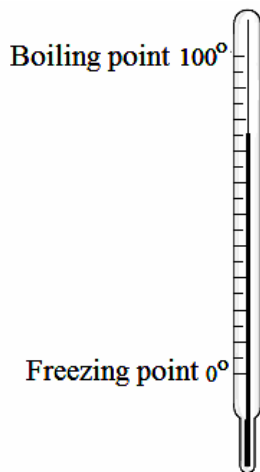

(A)

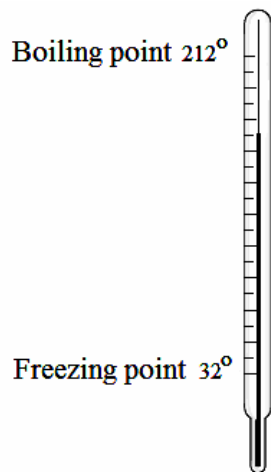

(B)

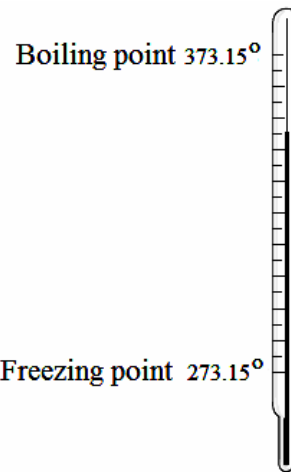

(C)

b. The reading of the thermometer (A) is approximately _____ (1 Mark)

Q.9.

(Total 5 Marks)

EITHER

- a. A person starts driving from his home to the petrol pump which is 1400 m away. After travelling 1600 m, he realizes that he has passed the petrol pump. He then turns his car and drives back to the pump and completes his journey to the pump in a total of 5 minutes.

Determine the total distance covered and the average speed of the car during his entire journey.

(Note: Extract data from the question and provide your answers in SI units.)

OR

- b. A stationary body acquires a velocity of 20 m/s after a force of 100 N acts on it for 5 s. Find the mass and the momentum of that body at 5 s.

(Note: Extract data from the question and provide your answers in SI units.)

Q.10.

(Total 5 Marks)

EITHER

a. The given graph shows the energy sources used by a small scale electricity generation plant from the year 2000 to 2010. In this graph, the electricity produced in mega-watt units is plotted on the y-axis while the time in years is on the x-axis.

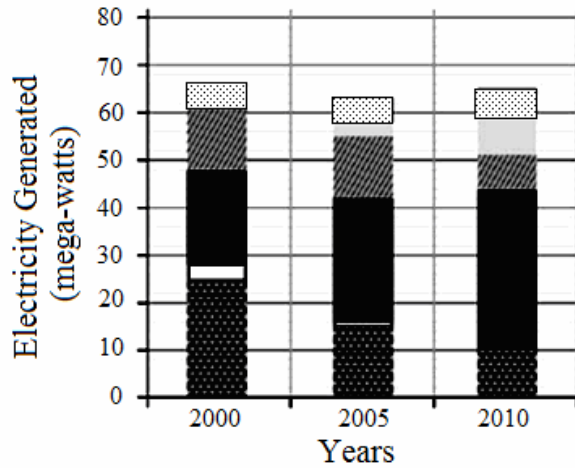

Coal
 Oil
 Gas
 Nuclear
 Wind
 Hydroelectric

- i. Name any ONE renewable energy source used for power generation shown in the graph.
- ii. Approximately how many mega-watts of electricity is generated from non-renewable energy sources in the year 2005?
- iii. Name the largest power generation source in the year 2010.
- iv. Highlight any TWO environmental issues associated with non-renewable energy sources.

Q.11.

(Total 5 Marks)

EITHER

- a. Evaporation occurs at all temperatures whereas boiling takes place at a specific temperature which varies depending on the external pressure. Justify the given statement.

OR

- b. Name the type of heat transfer in the given boxes and explain any ONE of them.

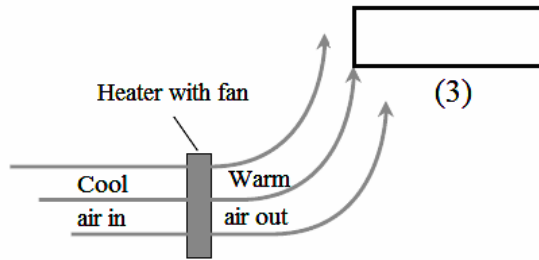
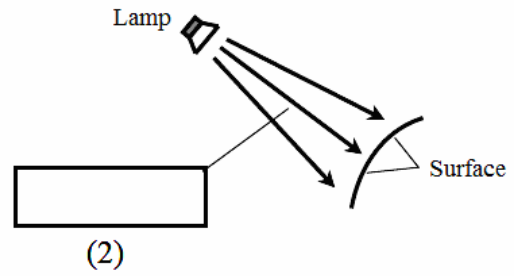
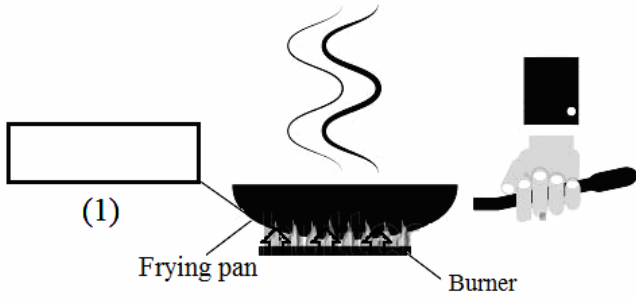

AGA KHAN UNIVERSITY EXAMINATION BOARD

SECONDARY SCHOOL CERTIFICATE

CLASS IX EXAMINATION

MAY 2016

Physics Paper II

Time: 2 hours 25 minutes Marks: 40

INSTRUCTIONS

Please read the following instructions carefully.

1. Check your name and school information. Sign if it is accurate.

**I agree that this is my name and school.
Candidate's signature**

2. **RUBRIC.** There are ELEVEN questions. Answer ALL questions. Questions 9, 10 & 11 each offer TWO choices. Attempt any ONE choice from each.
3. When answering the questions:

Read each question carefully.
Use a black pointer to write your answers. **DO NOT** write your answers in pencil.
Use a black pencil for diagrams. **DO NOT** use coloured pencils.
DO NOT use staples, paper clips, glue, correcting fluid or ink erasers.
Complete your answer in the allocated space only. **DO NOT** write outside the answer box.
4. The marks for the questions are shown in brackets ().
5. You may use a simple calculator if you wish.

Q.1. (Total 3 Marks)

Match the physical quantities in column A with the SI units in column B using arrows (\longrightarrow).

Column A	Column B
Intensity of light	Ampere
Temperature	Mole
Amount of substance	Kelvin
	Candela

Q.2. (Total 3 Marks)

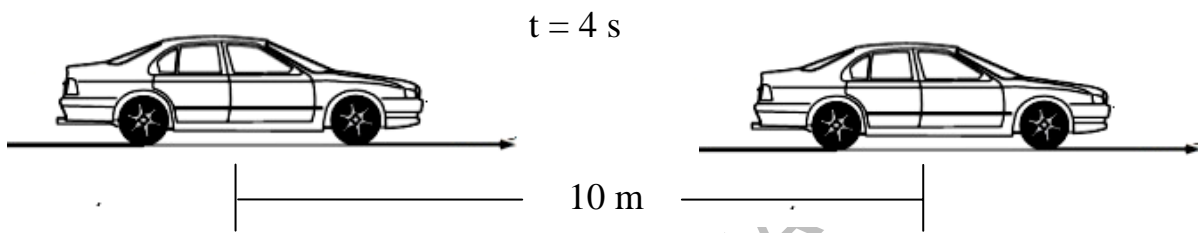

In the above diagram a car starts from rest and after time $t = 4 \text{ s}$ covers a distance of 10 m. Calculate the acceleration of the car.

Q.3.

(Total 3 Marks)

a. Describe the force which causes a ball to return back to the ground in TWO points. (2 Marks)

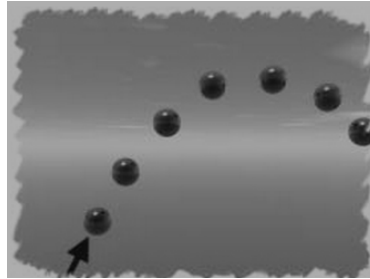

b. What is the difference between mass and weight? (1 Mark)

Mass	Weight

PLEASE TURN OVER THE PAGE

Q.4. (Total 3 Marks)

An automatic barrier is shown in the given diagram. The barrier arm is balanced by the block of weight **W**.

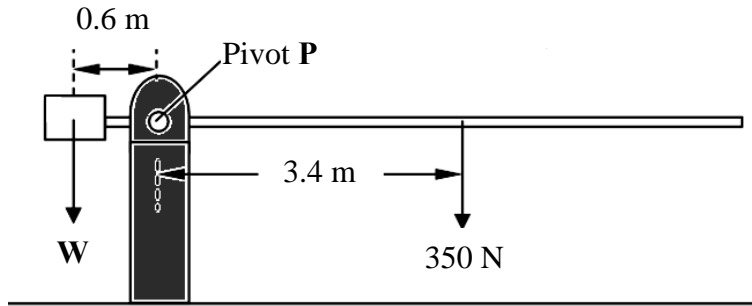

a. Using the data given in the above diagram, calculate the weight **W** of the block. (2 Marks)

b. State the principle which is applied to solve the above problem. (1 Mark)

Q.5.

(Total 3 Marks)

Two identical balls of masses m_1 and m_2 whereas ($m_1 = m_2$) are separated by a distance of r . If the distance between the two balls is doubled, form an equation proving that the gravitational force F_G between them will be decreased one-fourth of the initial force.

Q.6.

(Total 3 Marks)

A car of mass m starts moving from rest and covers a distance S . If the final velocity is v at time t , then derive an expression of kinetic energy for the car.

Q.7. (Total 3 Marks)

Given below are two identical beakers containing two different liquids of the same volume. An iron block of equal size is placed in each of the beakers.

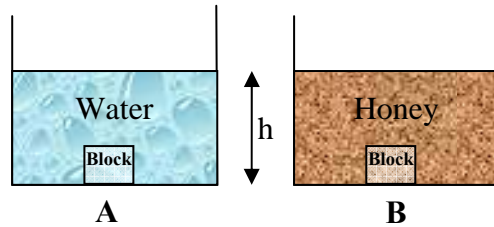

a. Define density. (1 Mark)

b. In which above given figure (A or B) the pressure on the block is greater? Justify your answer with the help of an equation. (2 Marks)

Q.8. (Total 4 Marks)

If the celsius thermometer shows the temperature of air as 30 °C at a certain day, then calculate the temperature of air in kelvin and fahrenheit.

Q.9.

(Total 5 Marks)

EITHER

- a. The given vector **F** is making an angle θ with the positive x -axis. Resolve the given vector **F** into its rectangular components. Also mention a formula for finding out the magnitude of a single vector and direction from its resolved components.

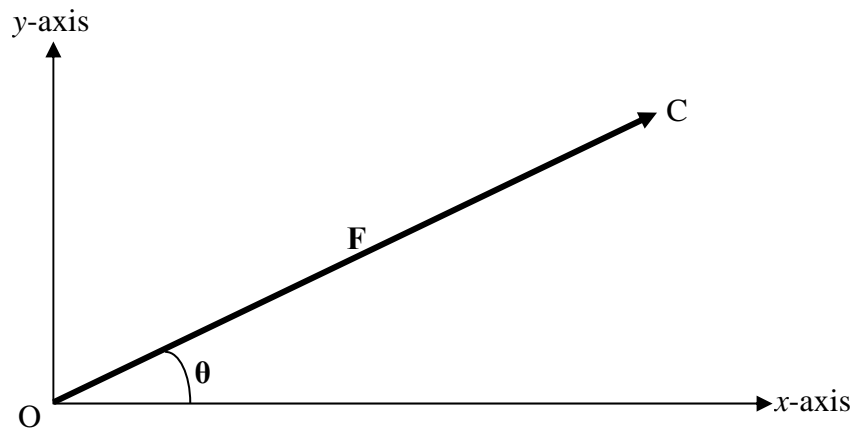

OR

- b. Two masses m_1 and m_2 are attached to the ends of a string that passes over a frictionless pulley.

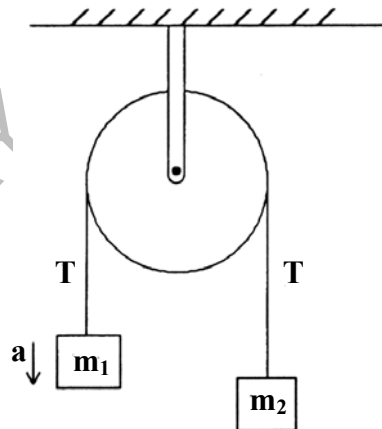

If m_1 is greater than m_2 , then determine the acceleration of the two masses when released. Show your answer in terms of m_1 , m_2 and g . (Where g = acceleration due to gravity)

PLEASE TURN OVER THE PAGE

Q.10.

(Total 5 Marks)

EITHER

- a. A block of ice having volume 10 m^3 hits the ground with the velocity of 2 m/s .
Find its kinetic energy in joules taking the density of ice block as 920 kg/m^3 .

OR

- b. Find the pressure due to the fluid at a depth of 10 cm in still water and in mercury.

(Note: The density of water and mercury is 1000 kg/m^3 and 13.6 g/cm^3 respectively.)

PLEASE TURN OVER THE PAGE

AGA KHAN UNIVERSITY EXAMINATION BOARD

SECONDARY SCHOOL CERTIFICATE

CLASS IX EXAMINATION

APRIL/ MAY 2017

Physics Paper II

Time: 2 hours 25 minutes Marks: 40

INSTRUCTIONS

Please read the following instructions carefully.

1. Check your name and school information. Sign if it is accurate.

**I agree that this is my name and school.
Candidate's signature**

2. RUBRIC. There are ELEVEN questions. Answer ALL questions. Questions 9, 10 & 11 each offer TWO choices. Attempt any ONE choice from each.
3. When answering the questions:

Read each question carefully.
Use a black pointer to write your answers. DO NOT write your answers in pencil.
Use a black pencil for diagrams. DO NOT use coloured pencils.
DO NOT use staples, paper clips, glue, correcting fluid or ink erasers.
Complete your answer in the allocated space only. DO NOT write outside the answer box.
4. The marks for the questions are shown in brackets ().
5. You may use a simple calculator if you wish.

Q.1. (Total 3 Marks)

Describe any THREE important contributions of physics in the field of technology.

Q.2. (Total 3 Marks)

Consider the given velocity-time graph for a body.

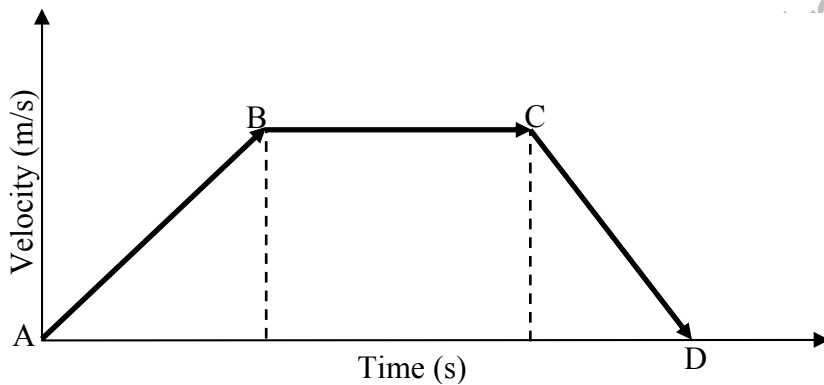

Interpret the following segments with respect to 'acceleration' from the given graph.

i. A to B (1 Mark)

ii. B to C (1 Mark)

iii. C to D (1 Mark)

Q.3.

(Total 3 Marks)

List any THREE methods of reducing friction.

AKU-EB May Examination 2017

PLEASE TURN OVER THE PAGE

Q.4. (Total 3 Marks)

Consider the given figure to answer the following questions.

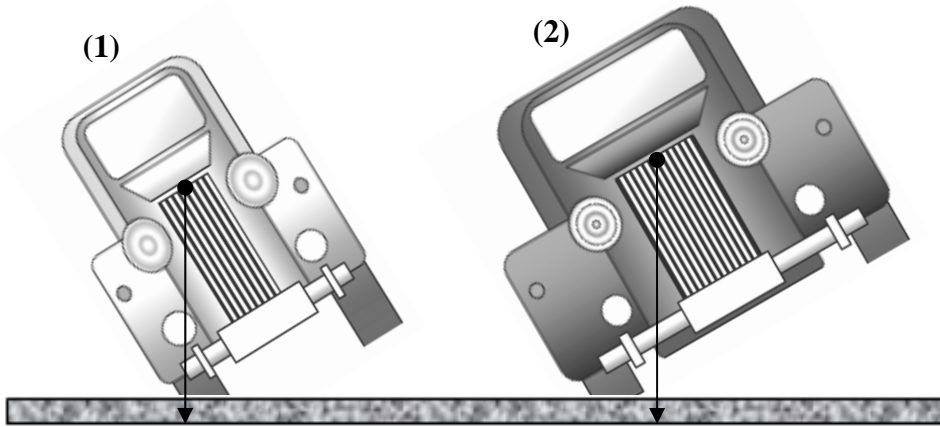

i. Identify the car which is more stable with reference to its centre of gravity (●). (1 Mark)

ii. For the car identified as more stable, write an effect of each of the following on its stability. (2 Marks)

- Position of the centre of gravity
- Area of the base

Q.5.

(Total 3 Marks)

Calculate the force of gravitation between the given balls.

(Note: The value of gravitational constant $G = 6.67 \times 10^{-11} \text{ Nm}^2/\text{kg}^2$.)

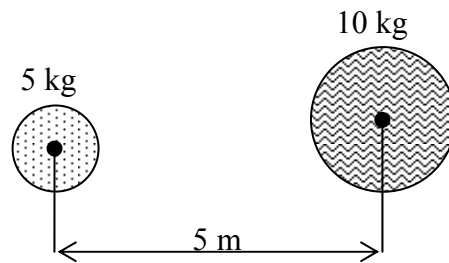

2017

AKU-2017

PLEASE TURN OVER THE PAGE

Q.6. (Total 3 Marks)

Identify the types of energy at positions 1, 2 and 3 in the given illustration of a thermal plant.

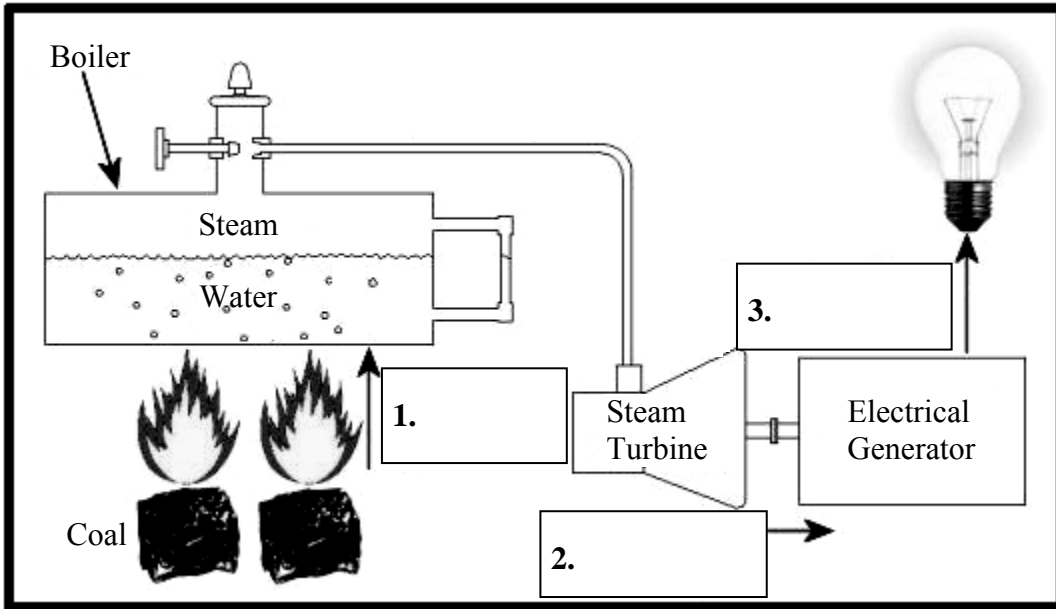

- 1. _____
- 2. _____
- 3. _____

Q.7.

(Total 3 Marks)

Calculate the pressure due to fluid at a depth of 10 cm in still water.

(Note: The density of water is 1000 kg/m^3 and the value of acceleration due to gravity is 10 m/s^2 .)

Q.8.

(Total 4 Marks)

A 4 cm thick cast iron sheet has a cross-sectional area of $10,000 \text{ cm}^2$. If one side of the sheet is at 500°C and the other is at 600°C , then how much amount of heat passes through the sheets in each second?

(Note: The thermal conductivity 'k' of cast iron is 85 W/m.K)

Q.9. (Total 5 Marks)

EITHER

- a. A boat travels toward south with a steady velocity of 30 m/s through a river in which there is a steady flow of water in the direction of the east at a velocity of 15 m/s.
- i. Illustrate the given situation using a labelled vector diagram. (1 Mark)
 - ii. Show the direction of the motion of the boat in the diagram. (1 Mark)
 - iii. Calculate the resultant velocity of the boat. (3 Marks)

OR

- b. An object of mass m is given an upward acceleration \vec{a} by pulling a rope.



- i. Label the following points in the given diagram. (2 Marks)
 - The direction of weight of the object
 - The direction of tension in the rope
- ii. If the object is moving upward and the weight is given by $F_w = mg$, then derive a simplified expression for the tension in the rope. (3 Marks)

Q.10.

(Total 5 Marks)

EITHER

- a. 'A working system cannot have an efficiency of 100%.'

Justify the given statement with reference to heat expels, heat transfers or Carnot limit.

OR

- b. Describe why the atmospheric pressure falls at a height above the sea level. Give your answer with reference to gravity, air compression and temperature of the surrounding.

AGA KHAN UNIVERSITY EXAMINATION BOARD

SECONDARY SCHOOL CERTIFICATE

CLASS IX EXAMINATION

APRIL/ MAY 2018

Physics Paper II

Time: 2 hours 25 minutes Marks: 40

INSTRUCTIONS

Please read the following instructions carefully.

1. Check your name and school information. Sign if it is accurate.

**I agree that this is my name and school.
Candidate's signature**

2. RUBRIC. There are ELEVEN questions. Answer ALL questions. Questions 9, 10 & 11 each offer TWO choices. Attempt any ONE choice from each.
3. When answering the questions:

Read each question carefully.
Use a black pointer to write your answers. DO NOT write your answers in pencil.
Use a black pencil for diagrams. DO NOT use coloured pencils.
DO NOT use staples, paper clips, glue, correcting fluid or ink erasers.
Complete your answer in the allocated space only. DO NOT write outside the answer box.
4. The marks for the questions are shown in brackets ().
5. You may use a simple calculator if you wish.

Q.1. (Total 3 Marks)

'Physics helps in the development of our society.' In light of the given statement, describe any THREE important roles of physics for the development of society.

Q.2. (Total 3 Marks)

The given speed-time graph shows the journey of a motorcyclist.

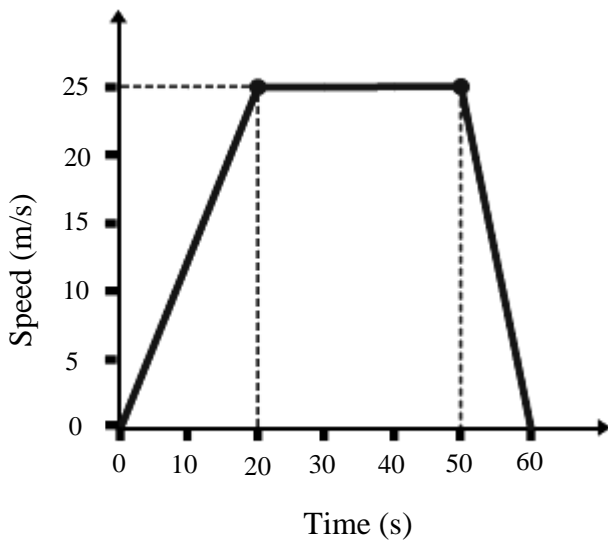

a. Calculate the acceleration of the motorcyclist in the first 20 seconds. (2 Marks)

b. The motorcyclist has constant speed for how many seconds? (1 Mark)

Q.3.

(Total 3 Marks)

A car has mass of 1000 kg and it moves in a circular path of radius 50 m with a constant speed of 25 m/s. Calculate the centripetal force of the car.

Q.4.

(Total 3 Marks)

The centre of gravity of a hollow sphere always lies within the hollow region of the object. Justify the given statement.

AKU-EB May 2013
Teaching & Learning Only

Q.5. (Total 3 Marks)

Differentiate between the orbit of a comet and the orbit of a planet in THREE points.

S. No.	Orbit of a Comet	Orbit of a Planet
1		
2		
3		

Q.6. (Total 3 Marks)

Calculate the efficiency in percentage of the light bulb shown in the given diagram.

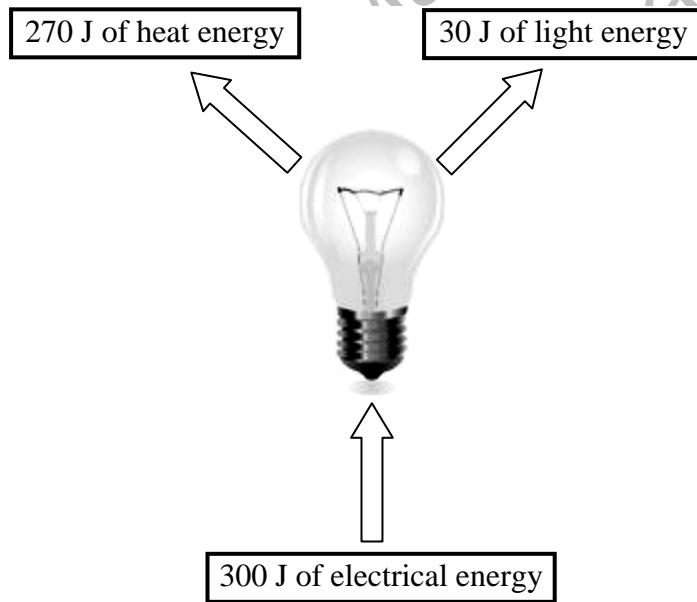

Q.7.

(Total 3 Marks)

In the given diagram, a test tube filled with mercury is inverted into a beaker that is also filled with mercury. Assume that the closed end of the test tube is a vacuum.

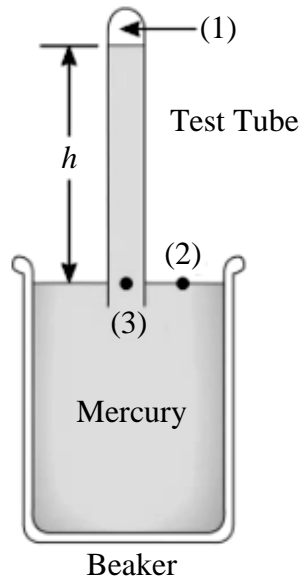

Compare the pressure at points (1), (2) and (3) for the given diagram.

PLEASE TURN OVER THE PAGE

Q.8. (Total 4 Marks)

If the length of a metallic conductor is 6 m; its area of cross section is 18 m^2 ; temperature difference between two surfaces of the conductor is 50 K and the rate of heat flow through the conductor is $40 \times 10^3 \text{ W}$, then calculate the thermal conductivity of the conductor.

AKC
Teaching
May
arn.

AGA KHAN UNIVERSITY EXAMINATION BOARD

SECONDARY SCHOOL CERTIFICATE

CLASS IX EXAMINATION

APRIL/ MAY 2019

Physics Paper II

Time: 2 hours 15 minutes Marks: 35

INSTRUCTIONS

Please read the following instructions carefully.

1. Check your name and school information. Sign if it is accurate.

**I agree that this is my name and school.
Candidate's Signature**

RUBRIC

2. There are TEN questions. Answer ALL questions. Questions 9 & 10 each offer TWO choices. Attempt any ONE choice from each.
3. When answering the questions:

Read each question carefully.
Use a black pointer to write your answers. DO NOT write your answers in pencil.
Use a black pencil for diagrams. DO NOT use coloured pencils.
DO NOT use staples, paper clips, glue, correcting fluid or ink erasers.
Complete your answer in the allocated space only. DO NOT write outside the answer box.
4. The marks for the questions are shown in brackets ().
5. You may use a simple calculator if you wish.

Q.1. (Total 2 Marks)

Write the name of the physical quantity which is measured by the given instruments.

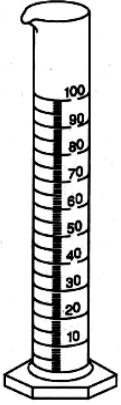

I

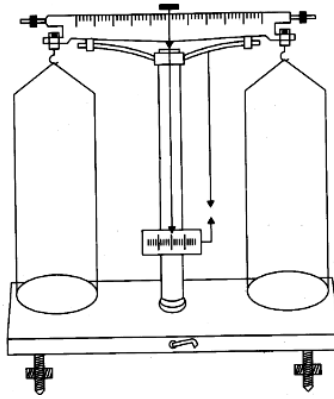

II

I _____

II _____

Q.2. (Total 3 Marks)

Differentiate between speed and velocity in any THREE points.

S. No.	Speed	Velocity
1		
2		
3		

Q.3.

(Total 3 Marks)

What happens when a very heavy ball collides head on with a light stationary ball on a flat surface?

Describe your answer on the basis of law of conservation of momentum.

Q.4.

(Total 2 Marks)

There are three states of equilibrium.

Write any ONE example of any two states of equilibrium from daily life. For each example, mention clearly which state of equilibrium is involved.

PLEASE TURN OVER THE PAGE

Q.5. (Total 3 Marks)

Consider the mass of the Earth and the Moon are 5.98×10^{24} kg and 7.35×10^{22} kg respectively.

The distance between the Earth and the Moon is 3.84×10^5 km.

The value of gravitational constant is 6.67×10^{-11} Nm²/kg².

Calculate the gravitational force exerted by the Earth on the Moon.

April/ May 2019
for
Teaching & Learning only

Q.6.

(Total 4 Marks)

What are the FOUR necessary steps to find the density of a stone with the help of the given apparatus?

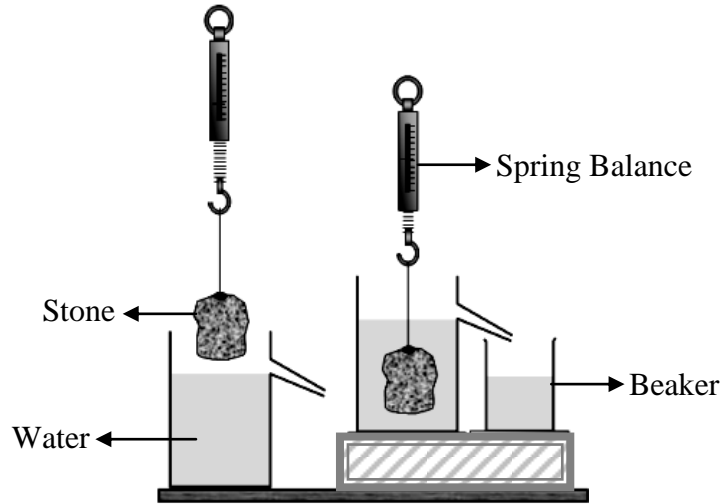

PLEASE TURN OVER THE PAGE

Q.7. (Total 4 Marks)

a. Define thermal expansion of solids. (1 Mark)

b. The temperature of a metal rim is increased before fixing it to a wooden cart wheel. Give a scientific reason to support this statement. (3 Marks)

Q.8. (Total 4 Marks)

a. An animal fur coat is made in such a way that the inner surface is animal's skin and the outer surface is fur/ hair. (2 Marks)

Why is this coat warmer if it is worn inside out (i.e. the inner surface becomes the outer)?

b. Walking barefoot on a carpet feels warmer than walking on tiles. Give a scientific reason to support this statement. (2 Marks)

AGA KHAN UNIVERSITY EXAMINATION BOARD

SECONDARY SCHOOL CERTIFICATE

CLASS IX

ANNUAL EXAMINATIONS (THEORY) 2023

Physics Paper II

Time: 1 hour 50 minutes Marks: 25

INSTRUCTIONS

Please read the following instructions carefully.

1. Check your name and school information. Sign if it is accurate.

**I agree that this is my name and school.
Candidate's Signature**

RUBRIC

2. There are SEVEN questions. Answer ALL questions. Questions 6 & 7 each offer TWO choices. Attempt any ONE choice from each.
3. When answering the questions:

Read each question carefully.
Use a black pointer to write your answers. DO NOT write your answers in pencil.
Use a black pencil for diagrams. DO NOT use coloured pencils.
DO NOT use staples, paper clips, glue, correcting fluid or ink erasers.
Complete your answer in the allocated space only. DO NOT write outside the answer box.
4. The marks for the questions are shown in brackets ().
5. You may use a simple calculator if you wish.

Q.1. (Total 2 Marks)

Write any TWO points about the importance of physics in science and technology.

Q.2. (Total 3 Marks)

Write any THREE examples of turning effect of force from daily life.

Q.3. (Total 2 Marks)

Two identical balls of masses m_1 and m_2 , whereas $m_1 = m_2$, are separated by a distance of r . If the distance between the two balls is doubled, then derive an equation to prove that the gravitational force F_G between them will be decreased one-fourth times of the initial force.

Q.4.

(Total 3 Marks)

Convert 100°F temperature into degree centigrade (°C) and Kelvin (K).

Q.5.

(Total 3 Marks)

A soldering iron is shown in the given diagram that is used to melt solder, for joining wires in an electrical circuit.

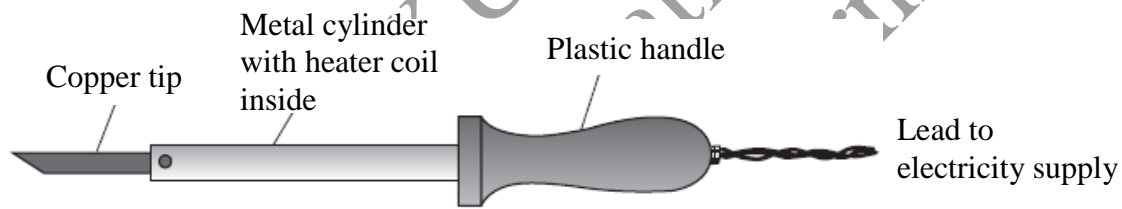

a. Why is the tip of soldering iron made up of copper? (1 Mark)

b. Why is the handle of soldering iron made up of plastic? (1 Mark)

c. Name the process by which heat transfers from the copper tip to the solder. (1 Mark)

PLEASE TURN OVER THE PAGE

AGA KHAN UNIVERSITY EXAMINATION BOARD

SECONDARY SCHOOL CERTIFICATE

CLASS IX

ANNUAL EXAMINATIONS (THEORY) 2024

Physics Paper II

Time: 1 hour 50 minutes Marks: 25

INSTRUCTIONS

Please read the following instructions carefully.

1. Check your name and school information. Sign if it is accurate.

**I agree that this is my name and school.
Candidate's Signature**

RUBRIC

2. There are SEVEN questions. Answer ALL questions. Questions 6 & 7 each offer TWO choices. Attempt any ONE choice from each.
3. When answering the questions:

Read each question carefully.
Use a black pointer to write your answers. DO NOT write your answers in pencil.
Use a black pencil for diagrams. DO NOT use coloured pencils.
DO NOT use staples, paper clips, glue correcting fluid, or ink erasers.
Complete your answer in the allocated space only. DO NOT write outside the answer box.
4. The marks for the questions are shown in brackets ().
5. You may use a simple calculator if you wish.

Q.1. (Total 2 Marks)

An online purchasing company delivered a fragile item to its customer in a triangular box. The breadth and height of the box was 15 cm and 20 cm respectively.

Calculate the volume of the triangular box upto two significant figures.

(Note: Volume (V) = Breadth \times Height)

Q.2. (Total 3 Marks)

A hanging picture frame is in a state of static equilibrium. The picture frame has a mass of 0.3 kg and is suspended from a single point by a thin wire.



If a small object of 0.1 kg is hung at any one corner from the bottom of the picture frame, then explain how the addition of the small object affects the balance of these forces and the stability of the picture frame.

Q.3.

(Total 2 Marks)

An apple falls on Earth due to the Earth's attraction force. However, the Earth does not show movement towards the apple.

Describe the given phenomenon in TWO points.

Q.4.

(Total 3 Marks)

Describe in THREE points, how evaporation causes cooling.

Q.5.

(Total 3 Marks)

Describe the transfer of heat through radiation in TWO points. Support your answer with an example.

PLEASE TURN OVER THE PAGE

Q.6. (Total 6 Marks)

EITHER

a. The following graph shows the path ABCDEF on which a boy walks.

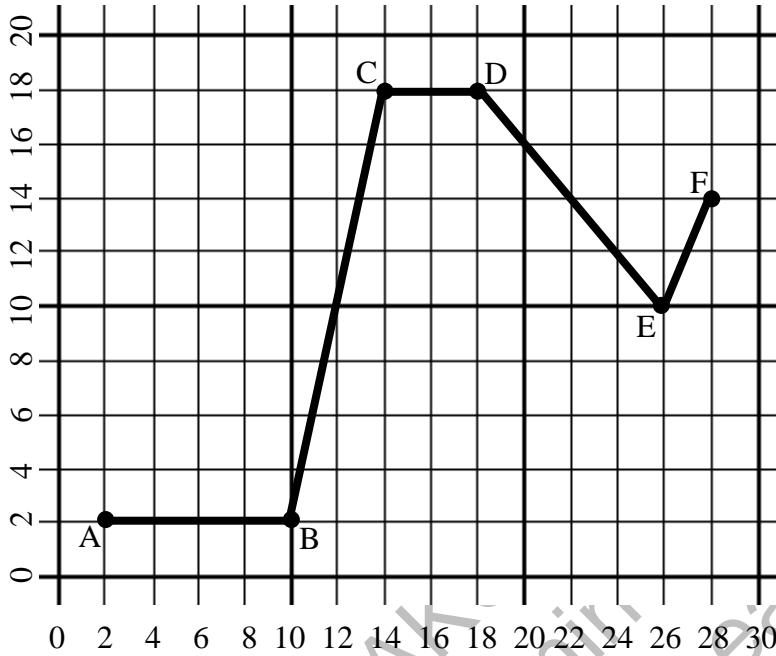

Using the above graph calculate the

- i. distance between A to B, B to C, C to D, D to E and E to F. (4 Marks)
- ii. total distance covered. (1 Mark)
- iii. total displacement covered. (1 Mark)

(Note: One small division is equal to one metre.)

OR

b. A sports bicycle acquires a velocity of 25 m/s from the state of rest when a force of 100 N acts on it for 5 s. Find

- i. the mass of the bicycle. (4 Marks)
- ii. the momentum of the bicycle after 5 s. (2 Marks)

(Note: Extract data from the question and provide your answers in SI units.)

Q.7. (Total 6 Marks)

EITHER

a. The diagram shows a block is dropped from a point **A** and moves to a point **B**.

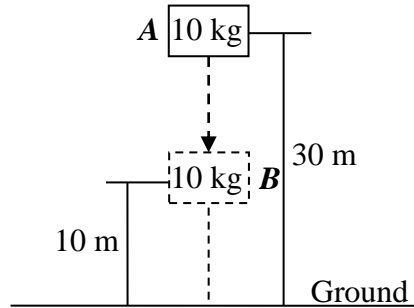

- i. Calculate the change in potential energy (P.E.) of the block at point **B** with respect to ground. (3 Marks)
- ii. Calculate the velocity of the block when it reaches to the point **B**. (3 Marks)

(Note: Take the value of acceleration due to gravity 'g' as 10 m/s².)

OR

b. The given figure shows the brake system of a vehicle.

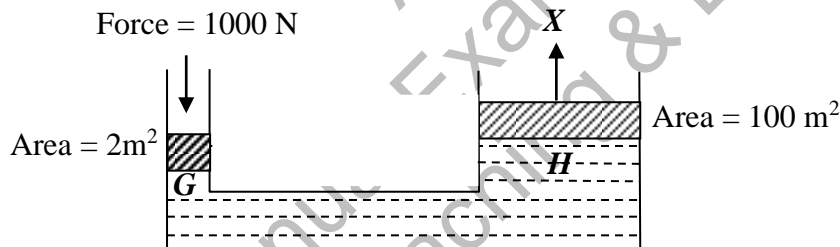

- i. Name the law which is used in the given brake system. (1 Mark)
- ii. Calculate the pressure exerted by the liquid at **G** and **H** and the force that is applied at **X**. (5 Marks)

AGA KHAN UNIVERSITY EXAMINATION BOARD

SECONDARY SCHOOL CERTIFICATE

CLASS IX

ANNUAL EXAMINATIONS (THEORY) 2025

Physics Paper II

Time: 1 hour 50 minutes Marks: 25

INSTRUCTIONS

Please read the following instructions carefully.

1. Check your name and school information. Sign if it is accurate.

**I agree that this is my name and school.
Candidate's Signature**

RUBRIC

2. There are SEVEN questions. Answer ALL questions. Questions 6 & 7 each offer TWO choices. Attempt any ONE choice from each.
3. When answering the questions:

Read each question carefully.
Use a black pointer to write your answers. DO NOT write your answers in pencil.
Use a black pencil for diagrams. DO NOT use coloured pencils.
DO NOT use staples, paper clips, glue correcting fluid, or ink erasers.
Complete your answer in the allocated space only. DO NOT write outside the answer box.
4. The marks for the questions are shown in brackets ().
5. You may use a simple calculator if you wish.

Q.1. (Total 2 Marks)

i. How many significant figures are there in 0.0102030? (1 Mark)

ii. List the rules of significant figures applied on the number given part (i). (1 Mark)

Q.2. (Total 3 Marks)

Describe the THREE states of equilibrium on the basis of centre of gravity.

Q.3. (Total 2 Marks)

The orbits of comets are large and elliptical as compared to the orbits of planets which are smaller and circular.

Describe the difference in the shapes of orbits with the help of TWO reasons.

Q.4.

(Total 3 Marks)

Write any THREE differences between evaporation and boiling.

S. No.	Evaporation	Boiling
1		
2		
3		

Q.5.

(Total 3 Marks)

A copper rod is 20 m long with the cross-sectional area of 4 m^2 . If its two ends are kept at temperatures 200°C and 300°C respectively, calculate the amount of heat flowing across the rod in one second.

(Note: Take the co-efficient of thermal conductivity as 386.4 J/m.K.s.)

PLEASE TURN OVER THE PAGE

AGA KHAN UNIVERSITY EXAMINATION BOARD
SECONDARY SCHOOL CERTIFICATE
CLASS IX
MODEL EXAMINATION PAPER 2026 AND ONWARDS
Physics Paper II
Time: 1 hour 50 minutes Marks: 25

EB 2026 ing only

INSTRUCTIONS:

1. Check your name and school information above. Sign if the information is correct.

I agree that this is my name and school.
Candidate's Signature

2. Read each question carefully.
3. There are SEVEN questions in this exam. Answer ALL questions. Questions 6 & 7 each offer TWO choices. For each of these questions, attempt ONE choice only.
4. When answering the questions:
 - Use a black pen/ pointer to write your answers. DO NOT write your answers in pencil.
 - Use a black pencil for diagrams and drawings. DO NOT use coloured pencils, markers or highlighters.
 - DO NOT use staples, paper clips, glue, correcting fluid, or ink erasers. If you make a mistake, cross it out neatly and write the correct answer beside it.
 - Write your answers only in the allocated space provided for each question.
 - DO NOT write outside the answer space. Answers written outside the allocated space will not be marked.
5. The marks for each question are shown in brackets () next to the question number. Use this information to manage your time efficiently.
6. DO NOT mention your name or school name anywhere inside the paper.
7. You may use a simple calculator if you wish.

Q.1. (Total 3 Marks)

Write the name of the physical quantity which is measured by the given instruments.

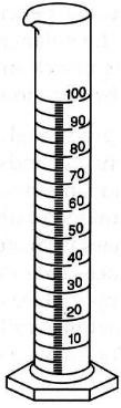

(i)

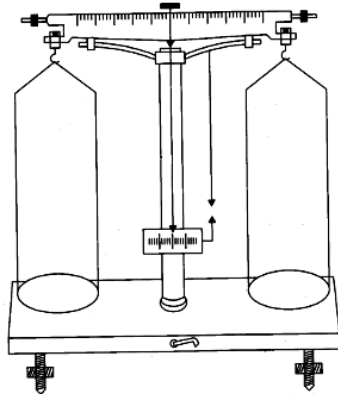

(ii)

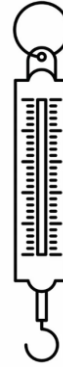

(iii)

(i) _____

(ii) _____

(iii) _____

Q.2. (Total 3 Marks)

There are three states of equilibrium.

Write any ONE example of each state of equilibrium from daily life.

Q.3.

(Total 3 Marks)

A student of class-IX performs an experiment to investigate the stretching of an elastic body by hanging different weights and measuring the extension.

The results of his/ her experiment are plotted in the given load-extension graph.

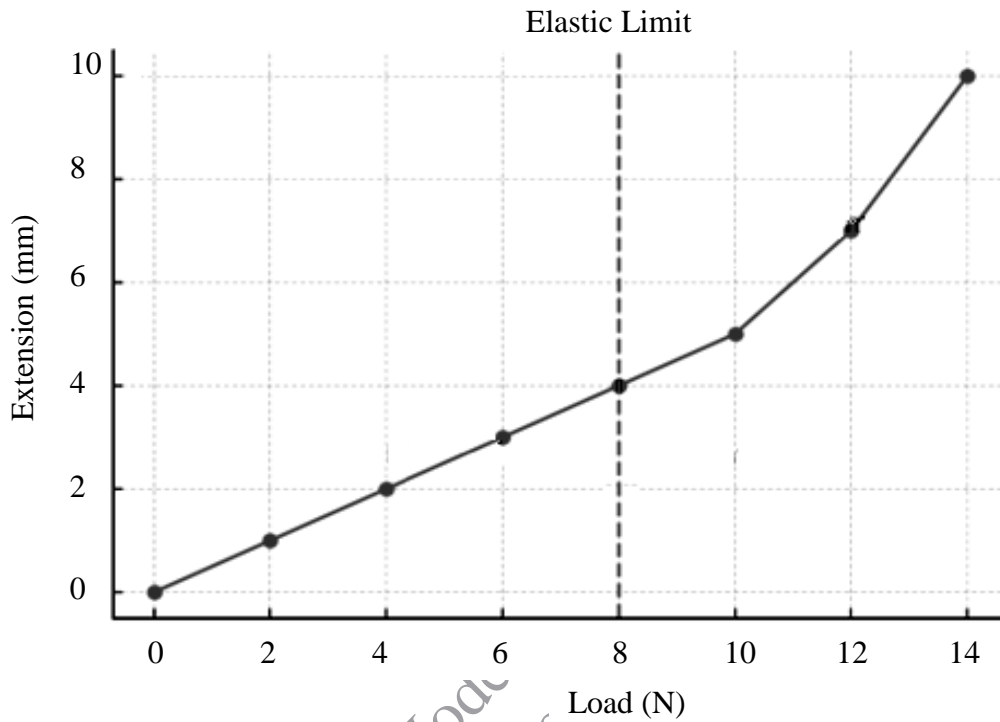

- i. Identify the law that explains the behaviour of an elastic body represented by straight line in the given graph. (1 Mark)

- ii. Give a reason for the change in behaviour of an elastic body after reaching its elastic limit. (1 Mark)

- iii. Infer the outcome when more loads are added after 14 N. (1 Mark)

Q.4. (Total 3 Marks)

In the given diagram, a test tube filled with mercury is inverted into a beaker that is also filled with mercury. Assume that the closed end of the test tube is a vacuum.

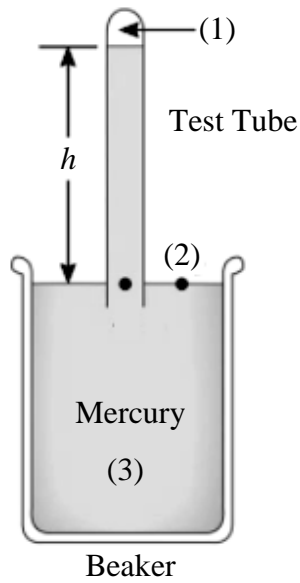

Write the pressure at points (1), (2) and (3) for the given diagram.

AKU-EB
Model Paper 2026
for Teaching and Learning only

Q.5.

(Total 3 Marks)

- a. An animal fur coat is made in such a way that the inner surface of the material is the animal's skin and the outer surface is fur/ hair.

State the reason why the coat is warmer if it is worn inside out (i.e., the inner surface becomes the outer)? (1 Mark)

- b. Walking barefoot on a carpet feels warmer than walking on tiles. Give a scientific reason to support this statement. (2 Marks)

AKU-EB
paper 2026
Learning only
M
for Teaching

Q.6. (Total 5 Marks)

EITHER

a. Motion of a sports car is shown in the given velocity-time graph.

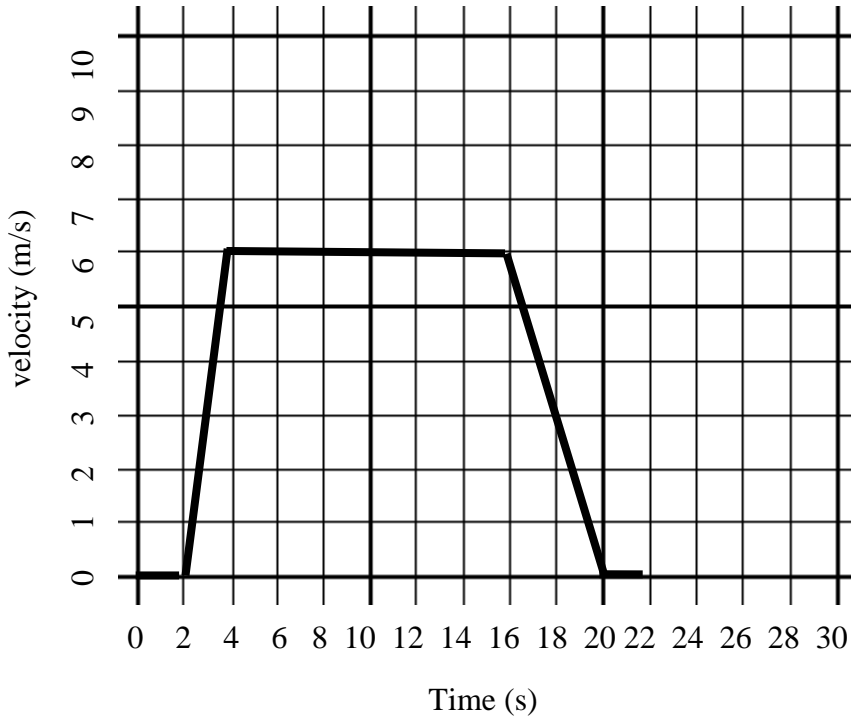

Interpret the graph and respond to the following questions:

- i. Explain the car's motion with respect to acceleration. (4 Marks)
- ii. Calculate the total displacement covered by the car. (1 Mark)

OR

b. Seatbelts and airbags are two safety features provided in cars to protect passengers during any accident.

- i. Explain these features with the help of the phenomenon of momentum. (3 Marks)
- ii. Relate the phenomenon of momentum to a person that jumps from a reasonable height. (2 Marks)
