

AGA KHAN UNIVERSITY EXAMINATION BOARD

SECONDARY SCHOOL CERTIFICATE

CLASS IX EXAMINATION 2008

Chemistry Paper I

Time allowed: 35 minutes Marks 25

INSTRUCTIONS

1. Read each question carefully.
2. Answer the questions on the separate answer sheet provided. Do NOT write your answers on the question paper.
3. There are 100 answer numbers on the answer sheet. Use answer numbers 1 to 25 only.
4. In each question there are four choices A, B, C, D. Choose ONE. On the answer grid black out the box for your choice with a pencil as shown below.

Correct Way				Incorrect Way					
1	A	B	C	D	1	A	B	C	D
	<input type="checkbox"/>	<input type="checkbox"/>	<input checked="" type="checkbox"/>	<input type="checkbox"/>		<input type="checkbox"/>	<input type="checkbox"/>	<input checked="" type="checkbox"/>	<input type="checkbox"/>
					2	A	B	C	D
						<input type="checkbox"/>	<input type="checkbox"/>	<input checked="" type="checkbox"/>	<input type="checkbox"/>
					3	A	B	C	D
						<input type="checkbox"/>	<input type="checkbox"/>	<input checked="" type="checkbox"/>	<input type="checkbox"/>
					4	A	B	C	D
						<input type="checkbox"/>	<input type="checkbox"/>	<input checked="" type="checkbox"/>	<input type="checkbox"/>

5. If you want to change your answer, ERASE the first answer completely with a rubber, before blacking out a new box.
6. Do NOT write anything in the answer grid. The computer only records what is in the boxes.

1. Cholera, typhoid fever and dysentery are dangerous diseases which are caused by
 - A. heavy water.
 - B. impure water.
 - C. pure water.
 - D. water vapours.
2. The quantity of matter contained in a body is called its mass. The unit of mass is
 - A. kilogram.
 - B. kilogram per cubic metre.
 - C. kilogram per cubic decimetre.
 - D. metre per second.
3. An element exists in atomic state and its symbol is ${}^{24}_{12}\text{Y}$. What will be its molar mass?
 - A. 12
 - B. 12g
 - C. 24g
 - D. 36g
4. A chemical substance breaks down into two or more simpler substances. The reaction is called
 - A. addition reaction.
 - B. combustion reaction.
 - C. decomposition reaction.
 - D. double displacement reaction.
5. A positive charge of 1.602×10^{-19} and a mass of 1.672×10^{-27} kg are the properties of
 - A. an alpha particle.
 - B. an electron.
 - C. a neutron.
 - D. a proton.
6. The number of isotopes of hydrogen is
 - A. one.
 - B. two.
 - C. three.
 - D. four.
7. $1s^2 2s^2 2p^6 3s^1$ is the electronic configuration of
 - A. chlorine.
 - B. oxygen.
 - C. sodium.
 - D. sulphur.

8. In the VII-A group of the modern periodic table, the number of elements is
- A. eight.
 - B. five.
 - C. seven.
 - D. six.
9. All of the elements of group VII-A have the same
- A. number of protons.
 - B. number of neutrons.
 - C. number of proton and neutrons.
 - D. valence.
10. As we move from left to right in the periodic table, the nature of the oxides changes from
- A. basic to strongly acidic.
 - B. acidic to strongly basic.
 - C. acidic to amphoteric.
 - D. basic to neutral.
11. Which one of the following can be explained by hydrogen bonding?
- A. Ice floats on water.
 - B. Hydrogen sulphide is an acid in aqueous solution.
 - C. Liquid ammonia is a good solvent for polar compounds.
 - D. The molecule of methane has tetrahedral shape.
12. The bond which is formed by one sided sharing of a pair of electrons is called a
- A. chemical bond.
 - B. co-ordinate covalent bond.
 - C. covalent bond.
 - D. ionic bond.

13.

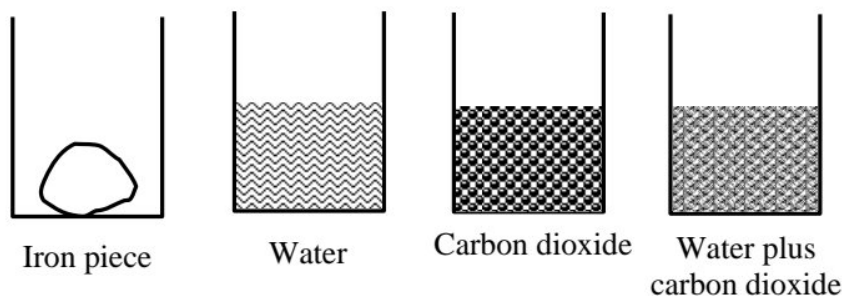

Which of the matters above has a high density?

- A. Iron piece
- B. Water
- C. Carbon dioxide
- D. Water plus carbon dioxide

PLEASE TURN OVER THE PAGE

14. The temperature at which a solid changes into a liquid, is called its
- A. boiling point.
 - B. evaporation point.
 - C. melting point.
 - D. sublimation point.
15. The mass of solute of sodium hydroxide required per dm^3 for a bimolar solution is
- A. 20 g.
 - B. 40 g.
 - C. 60 g.
 - D. 80 g.
16. A solution which can dissolve a further amount of solute is called
- A. a saturated solution.
 - B. an unsaturated solution.
 - C. a standard solution.
 - D. a super saturated solution.
17. If the concentration of a solution is known, it is called a
- A. concentrated solution.
 - B. diluted solution.
 - C. standard solution.
 - D. saturated solution.
18. When electric current is passed through a fused ionic compound or its aqueous solution, it is decomposed into its constituents. Such a compound is called a/an
- A. electrolysis.
 - B. electrolyte.
 - C. electroplate.
 - D. non-electrolyte.
19. Which of the following is an example of a strong electrolyte?
- A. NaOH
 - B. H_2CO_3
 - C. CH_3COOH
 - D. NH_4OH
20. Crystalline magnesium sulphate is also called
- A. basic salt.
 - B. double salt.
 - C. epsom salt.
 - D. potash alum.

21. When NaOH reacts with H_2SO_4 , which compounds are formed?
- A. $\text{NaSO}_4 + \text{H}_2\text{O}$
 - B. $\text{NaHSO}_4 + \text{H}_2\text{O}$
 - C. $\text{Na}_2\text{HSO}_4 + \text{H}_2\text{O}$
 - D. $\text{NaH}_2\text{SO}_4 + \text{H}_2\text{O}$
22. Which organic acid is found in fermented milk?
- A. Acetic acid
 - B. Citric acid
 - C. Lactic acid
 - D. Tartaric acid
23. The enthalpy of a substance depends upon two factors, the physical state of the substance and
- A. evaporation.
 - B. pressure.
 - C. temperature.
 - D. sublimation.
24. In endothermic reactions energy is absorbed from the surroundings. Thus the container in which the reaction takes place becomes
- A. hot.
 - B. cold.
 - C. moderate.
 - D. active.
25. When sufficient volumes of an acid and a base react to produce one mole of water, the heat evolved is called the heat of
- A. hydration.
 - B. crystallisation.
 - C. neutralisation.
 - D. standardisation.

AGA KHAN UNIVERSITY EXAMINATION BOARD

SECONDARY SCHOOL CERTIFICATE

CLASS IX EXAMINATION 2009

Chemistry Paper I

Time allowed: 35 minutes Marks 25

INSTRUCTIONS

1. Read each question carefully.
2. Answer the questions on the separate answer sheet provided. DO NOT write your answers on the question paper.
3. There are 100 answer numbers on the answer sheet. Use answer numbers 1 to 25 only.
4. In each question there are four choices A, B, C, D. Choose ONE. On the answer grid black out the box for your choice with a pencil as shown below.

Correct Way				Incorrect Way					
1	A	B	C	D	1	A	B	C	D
	<input type="checkbox"/>	<input type="checkbox"/>	<input checked="" type="checkbox"/>	<input type="checkbox"/>		<input type="checkbox"/>	<input type="checkbox"/>	<input checked="" type="checkbox"/>	<input type="checkbox"/>
					2	A	B	C	D
	<input type="checkbox"/>	<input type="checkbox"/>	<input type="checkbox"/>	<input type="checkbox"/>		<input type="checkbox"/>	<input type="checkbox"/>	<input checked="" type="checkbox"/>	<input type="checkbox"/>
					3	A	B	C	D
	<input type="checkbox"/>	<input type="checkbox"/>	<input checked="" type="checkbox"/>	<input type="checkbox"/>		<input type="checkbox"/>	<input type="checkbox"/>	<input checked="" type="checkbox"/>	<input type="checkbox"/>
					4	A	B	C	D
	<input type="checkbox"/>	<input type="checkbox"/>	<input checked="" type="checkbox"/>	<input type="checkbox"/>		<input type="checkbox"/>	<input type="checkbox"/>	<input checked="" type="checkbox"/>	<input type="checkbox"/>

5. If you want to change your answer, ERASE the first answer completely with a rubber, before blacking out a new box.
6. DO NOT write anything in the answer grid. The computer only records what is in the boxes.

- Who is most likely to establish the contents of calcium medicine?
 - An analytical chemist
 - An inorganic chemist
 - An organic chemist
 - A biochemist
- Which fundamental quantity is used to derive the SI unit of volume?
 - Area
 - Length
 - Mass
 - Time
- Which of the following is an example of a chemical change?
 - Burning a scented candle
 - Cutting a pear into slices
 - Freezing liquid water into an ice cube
 - Mixing of iron filings and sulphur
- Which of the following has the most mass?
 - 1 mole of H_2
 - 1 mole of He
 - 2 moles of K
 - 3 moles of Mg
- Which of the following describes a particle that contains 26 electrons, 39 neutrons and 28 protons?
 - An ion with a charge of -2
 - An ion with a charge of +2
 - An atom with a mass of 38 amu
 - An atom with a mass of 49 amu
- When alpha particles are used to bombard gold foil; most of the alpha particles pass through undeflected. This result indicates that most of the volume of a gold atom consists of
 - electrons.
 - neutrons.
 - occupied space.
 - unoccupied space.

- Deuterium (2H_1) and protium (1H_1) are two isotopes of hydrogen. Which of the following differences between deuterium and protium atoms is true?
 - The deuterium atom has a smaller net charge
 - The deuterium atom has more electron orbitals
 - The deuterium atom has a smaller atomic radius
 - The deuterium atom has more particles in its nucleus

- The bar graph below represents four elements and their atomic numbers.

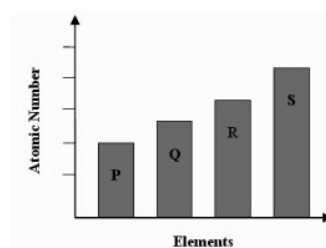

What will be the **most likely** positioning of these unknown elements in the periodic table?

- | |
|---|
| P |
| Q |
| R |
| S |
 - | | |
|---|---|
| P | Q |
| R | S |
 - | |
|---|
| P |
| Q |
| R |
| S |
 - | | | | |
|---|---|---|---|
| P | Q | R | S |
|---|---|---|---|
- Which property describes the order of the elements in the periodic table?
 - Mass of atoms
 - Number of electrons in the outer shell
 - Number of protons in the nucleus
 - Number of neutrons in the nucleus

10. Atoms of element A and atoms of element B react to form a compound. In the reaction, the radius of each atom of element A is decreased.

Which of the following explains the decrease in atomic radius in the reaction?

- A. Element A loses electrons to element B
 B. Element A gains neutrons from element B
 C. Protons are converted into energy in element A
 D. Protons become more densely packed in the nuclei of element A
11. The diagram below represents particles of different elements in a crystal.

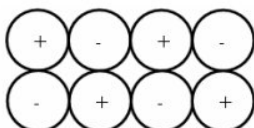

What type of bond holds these particles together?

- A. Covalent
 B. Hydrogen
 C. Ionic
 D. Polar
12. A hydrogen bond is formed with any of the following elements **EXCEPT**
- A. Chlorine.
 B. Fluorine.
 C. Oxygen.
 D. Sulphur.
13. Three 10 g samples of sugar are shown below.

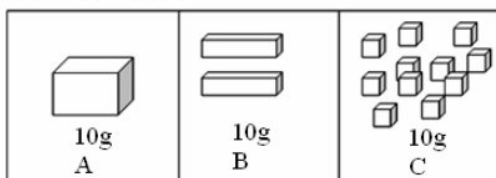

Among all the samples shown, sample A dissolves most slowly. The reason is that it has the

- A. most volume.
 B. smallest surface area.
 C. largest number of molecules.
 D. fewest bonds between molecules.

14. The graph below compares three states of a substance.

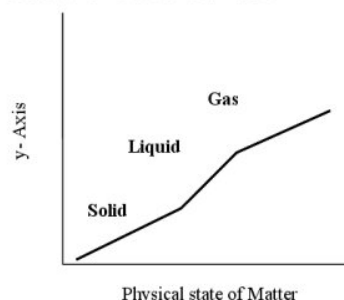

Which of the following is the label for the y-axis?

- A. Molecular density
 B. Molecular motion
 C. Neutron density
 D. Neutron motion
15. What is the total number of moles of H_2SO_4 needed to prepare 5.0 liters of a 2.0M solution of H_2SO_4 ?
- A. 2.5 moles
 B. 5.0 moles
 C. 10 moles
 D. 20 moles
16. Which of the following defines an unsaturated solution?
- A. Stable because it has dissolved more solute
 B. Unstable because it has dissolved more solute
 C. Has dissolved exactly as much solute as is theoretically possible
 D. Hasn't dissolved exactly as much solute as is theoretically possible
17. Which acid is used to prevent the hydrolysis of CuSO_4 during copper plating?
- A. Carbonic acid
 B. Hydrochloric acid
 C. Nitric acid
 D. Sulphuric acid

PLEASE TURN OVER THE PAGE

18. The both figures represent below

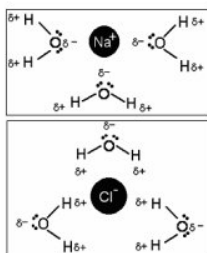

- A. hydrated ions.
B. dissolute ions.
C. positive ions.
D. negative ions.

19. In the electrolysis of water, hydrogen ions H^+ (aq)

- A. gain electrons at negative electrode.
B. lose electrons at negative electrode.
C. gain electrons at positive electrode.
D. lose electrons at positive electrode.

20. Hydrochloric acid + **Y** \rightarrow salt + water + carbon dioxide
What is the reactant **Y**?

- A. Calcium carbonate
B. Calcium chloride
C. Calcium oxide
D. Calcium hydroxide

21. The water from hot springs near a mountainous valley has a very low pH.

What is represented by a low pH?

- A. It has no detectable H^+ or OH^- ions.
B. It has high concentrations of H^+ ions.
C. It has equal concentrations of H^+ and OH^- ions
D. It has equal numbers of positive and negative ions.

22. The table below shows the pH values of samples of substances.

Substance	pH
Drain cleaner	14.0
Distilled water	7.0
Rain water	5.8
Soda water	3.0

According to the table, which of these substances is strongly acidic?

- A. Drain cleaner
B. Distilled water
C. Rain water
D. Soda water

23. Which one of the following is an example of exothermic reaction?

- A. Electrolysis
B. Neutralization
C. Photosynthesis
D. Thermal decomposition

24. Which of the following energy profile diagrams shows exothermic reaction?

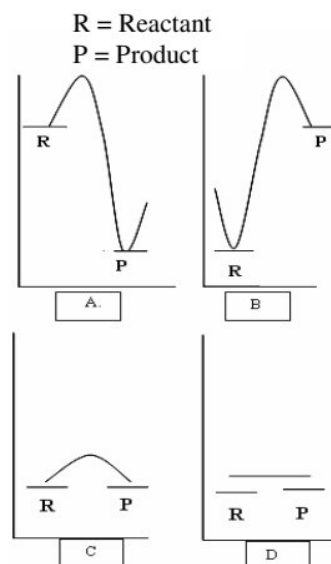

25. The energy level diagram shows a reaction.
What does it mean?

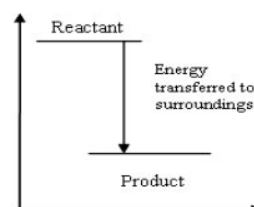

- A. The reaction is endothermic.
B. The heat energy is transferred to the system.
C. The product has more energy than the reactants.
D. The product has less energy than the reactants

AGA KHAN UNIVERSITY EXAMINATION BOARD

SECONDARY SCHOOL CERTIFICATE

CLASS IX EXAMINATION 2010

Chemistry Paper I

Time allowed: 35 minutes Marks 25

INSTRUCTIONS

1. Read each question carefully.
2. Answer the questions on the separate answer sheet provided. DO NOT write your answers on the question paper.
3. There are 100 answer numbers on the answer sheet. Use answer numbers 1 to 25 only.
4. In each question there are four choices A, B, C, D. Choose ONE. On the answer grid black out the box for your choice with a pencil as shown below.

Correct Way				Incorrect Way					
1	A	B	C	D	1	A	B	C	D
	<input type="checkbox"/>	<input type="checkbox"/>	<input checked="" type="checkbox"/>	<input type="checkbox"/>		<input type="checkbox"/>	<input type="checkbox"/>	<input checked="" type="checkbox"/>	<input type="checkbox"/>
					2	A	B	C	D
						<input type="checkbox"/>	<input type="checkbox"/>	<input type="checkbox"/>	<input checked="" type="checkbox"/>
					3	A	B	C	D
						<input type="checkbox"/>	<input type="checkbox"/>	<input checked="" type="checkbox"/>	<input type="checkbox"/>
					4	A	B	C	D
						<input type="checkbox"/>	<input type="checkbox"/>	<input checked="" type="checkbox"/>	<input type="checkbox"/>

5. If you want to change your answer, ERASE the first answer completely with a rubber, before blacking out a new box.
6. DO NOT write anything in the answer grid. The computer only records what is in the boxes.
7. You may use a simple calculator if you wish.

1. Ingredients of baking powder are listed below.

Baking Powder Ingredients

Corn starch =4gms
 Sod. Bicarbonate = 0.2gms
 Calcium acid phosphate =0.01gms
 Sod. Aluminum Sulphate = 0.09gms

Baking powder is classified as a/an

- A. amalgam.
 B. compound.
 C. heterogenous mixture.
 D. homogenous mixture.
2. Which type of chemical reaction occurs when zinc metal reacts with dilute sulphuric acid?
- A. Addition reaction
 B. Decomposition reaction
 C. Displacement reaction
 D. Double displacement reaction
3. A charged group of atoms which behaves as a single unit in a chemical reaction is known as a
- A. radical.
 B. molecule.
 C. complex molecule.
 D. formula unit.
4. The mass of an atom of an element depends upon the number of its
- A. protons and electrons.
 B. protons and neutrons.
 C. electrons and neutrons.
 D. protons, neutrons and electrons.

5. How many electrons are present in the outermost shell of chlorine? (atomic.mass of Cl=35)

A. 5
 B. 6
 C. 7
 D. 8

6. A local scientist discovered an element and named it Pakistanium (Pk) which contains 111 protons and 141 neutrons.

Which of the following is the correct representation of an atom of Pakistanium?

A. ${}_{30}\text{Pk}^{141}$
 B. ${}_{30}\text{Pk}^{111}$
 C. ${}_{111}\text{Pk}^{141}$
 D. ${}_{111}\text{Pk}^{252}$

7. How many orbitals are present in the p-subshell of an atom?

A. 1
 B. 2
 C. 3
 D. 4

8. The elements in the modern periodic table are arranged in order of their

A. atomic size.
 B. atomic number.
 C. atomic mass.
 D. date of discovery.

9. Which of the following properties decreases in a period from left to right in a periodic table?

A. Atomic radii
 B. Nuclear charge
 C. Electronegativity
 D. Ionization energy

10. Identify the d-block elements in the given periodic table.

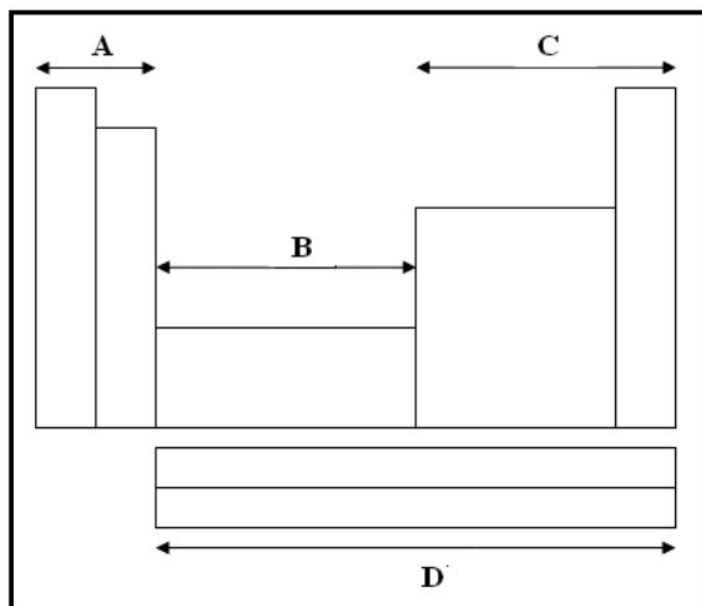

11. During the formation of an ionic bond, atoms
- gain protons.
 - gain electrons.
 - lose electrons.
 - gain and lose electrons.
12. Which of the following bonds is formed when a molecule donates an electron pair to another molecule?
- Ionic bond
 - Covalent bond
 - Metallic bond
 - Co-ordinate covalent bond
13. Which of the following molecules contain polar covalent bonds?
- Ammonia
 - Chlorine
 - Hydrogen
 - Oxygen
14. Which of the following is classified as a weak force of interaction?
- Ionic bond
 - Covalent bond
 - Hydrogen bond
 - Metallic bond
15. Which of the following processes involves the increase of kinetic energy of molecules of a liquid by heating?
- Condensation
 - Evaporation
 - Sublimation
 - Melting
16. All of the following are examples of amorphous solids EXCEPT
- glass.
 - rubber.
 - plastic.
 - sulphur.
17. Which of the following types of solution is found in carbonated water?
- Gas and solid
 - Gas and liquid
 - Liquid and solid
 - Liquid and liquid
18. All of the following are insoluble in water EXCEPT
- benzene.
 - methanol.
 - chloroform.
 - kerosine oil.
19. How many moles of solute are present in 1 dm^3 of 2 M solution?
- 0 mole
 - 1 mole
 - 2 moles
 - 3 moles
20. A theory which explains the process of electrolysis is called
- ionic.
 - current.
 - covalent.
 - co-ordinate covalent.

PLEASE TURN OVER THE PAGE

21. Name the species which gets reduced in the equation given below.

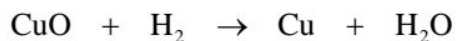

- A. Cu
 - B. CuO
 - C. H₂O
 - D. H₂
22. What products are formed when sodium metal reacts with water?
- A. Sodium oxide and hydrogen
 - B. Sodium hydroxide and hydrogen
 - C. Sodium hydroxide and oxygen
 - D. Sodium hydride and oxygen

23. Which of the following have a low melting point?

- A. Metals
- B. Metalloids
- C. Non-metals
- D. Transition metals

24. When Ca and Mg burn in air they form

- A. acidic oxide.
- B. basic oxide.
- C. neutral oxide.
- D. amphoteric oxide.

25. The alkali metals are more reactive because of their

- A. high ionization energy.
- B. low ionization energy.
- C. high electronegativity.
- D. high electron affinity.

AGA KHAN UNIVERSITY EXAMINATION BOARD

SECONDARY SCHOOL CERTIFICATE

CLASS IX EXAMINATION

MAY 2011

Chemistry Paper I

Time allowed: 35 minutes Marks 25

INSTRUCTIONS

1. Read each question carefully.
2. Answer the questions on the separate answer sheet provided. DO NOT write your answers on the question paper.
3. There are 100 answer numbers on the answer sheet. Use answer numbers 1 to 25 only.
4. In each question there are four choices A, B, C, D. Choose ONE. On the answer grid black out the box for your choice with a pencil as shown below.

Correct Way				Incorrect Way					
1	A	B	C	D	1	A	B	C	D
	<input type="checkbox"/>	<input type="checkbox"/>	<input checked="" type="checkbox"/>	<input type="checkbox"/>		<input type="checkbox"/>	<input type="checkbox"/>	<input checked="" type="checkbox"/>	<input type="checkbox"/>
					2	A	B	⊙	D
						<input type="checkbox"/>	<input type="checkbox"/>	<input checked="" type="checkbox"/>	<input type="checkbox"/>
					3	A	B	X	D
						<input type="checkbox"/>	<input type="checkbox"/>	<input checked="" type="checkbox"/>	<input type="checkbox"/>
					4	A	B	/	D
						<input type="checkbox"/>	<input type="checkbox"/>	<input checked="" type="checkbox"/>	<input type="checkbox"/>

5. If you want to change your answer, ERASE the first answer completely with a rubber, before blacking out a new box.
6. DO NOT write anything in the answer grid. The computer only records what is in the boxes.
7. You may use a simple calculator if you wish.

1. The relative atomic mass of nitrogen present in a molecule of ammonia is

- A. 14 amu.
- B. 17 amu.
- C. 24 amu.
- D. 28 amu.

2. Which of the following types of reaction is shown below?

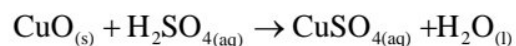

- A. Addition
- B. Combustion
- C. Decomposition
- D. Neutralisation

3. Supply the co-efficients necessary to balance the equation below.

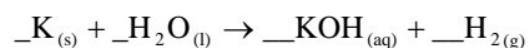

- A. 2:2:2:1
- B. 1:2:1:2
- C. 2:1:2:1
- D. 1:2:2:2

4. The charge on the molecular ion shown in the diagram will be

- A. -1
- B. -2
- C. $+1$
- D. $+2$

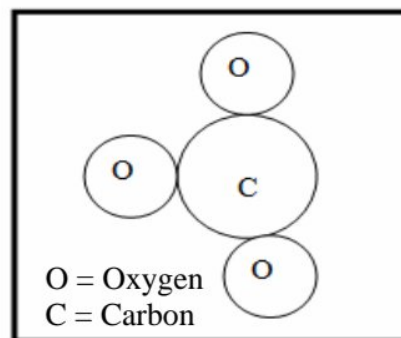

5. Which of the following configurations represents an Mg^{2+} ion ?

- A. $1s^2 2s^2 2p^6 3s^2$
- B. $1s^2 2s^2 2p^6 3s^1$
- C. $1s^2 2s^2 2p^6$
- D. $1s^2 2s^2 2p^2$

6. Chlorine has two isotopes which may be represented as ^{37}Cl and ^{35}Cl .

Which of the given information about ^{37}Cl is correct?

	Proton	Neutron	Electron
A	17	17	20
B	20	17	20
C	17	20	17
D	17	20	20

7. The given atomic structure is of

- A. boron.
B. carbon.
C. lithium.
D. sodium.

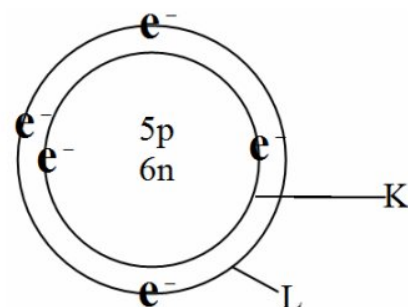

8. Which of the following statements about the periodic table are correct?
- I. Elements are arranged in order of increasing atomic mass
II. A period is a horizontal row
III. The properties of the elements within a period vary from element to element.
- A. I and II only
B. I and III only
C. II and III only
D. I, II and III
9. When we go down the group VII, the elements
- A. become more reactive.
B. become bigger in size.
C. become mono atomic.
D. attain low melting and boiling points.
10. Which of the following represents the compound of a transition metal?

Metal	Melting point	Colour of the compound
A	High	Blue
B	Low	Green
C	High	White
D	Low	White

PLEASE TURN OVER THE PAGE

11. Which type of bond is shown in the given figure?

- A. Ionic
- B. Covalent
- C. Co-ordinate covalent
- D. Metallic

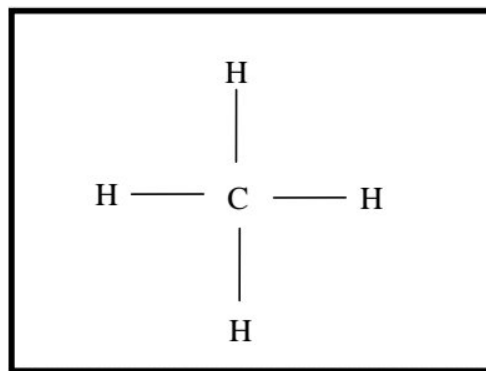

12. How many pi-electrons are found between C=C in the following compound?

- A. 2
- B. 3
- C. 4
- D. 5

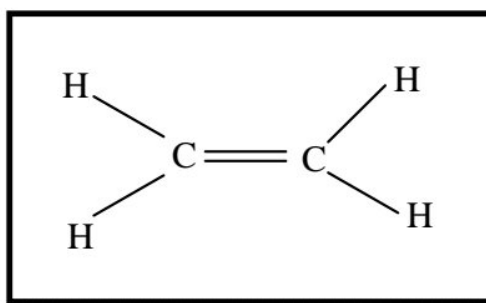

13. Which of the following does NOT conduct electricity?

- A. Molten NaOH
- B. Molten KOH
- C. Solid NaCl
- D. Aqueous NaCl

14. Which of the following is an example of diffusion?

- A. Bubbles rising in a beaker of boiling water
- B. Fragrance of flowers in a garden
- C. Swelling of raisins in water
- D. Steam condensing on a cold window

15. When impurities is added into water, the boiling point of the water

- A. increases.
- B. decreases.
- C. remains unchanged.
- D. becomes unpredictable.

16. Which of the following is responsible for change of state in matter?

- A. Density
- B. Mass
- C. Pressure
- D. Temperature

17. If 21 cm^3 of alcohol is present in 70 cm^3 of its aqueous solution, the percentage by volume of alcohol will be
- 21%
 - 20%
 - 30%
 - 35%
18. Which of the following information shows that the solution is supersaturated?

Type of solution	Compound	Temperature	Mass of solute in 100 ml of water
A	NH_3	90°C	10g
B	NH_4Cl	80°C	70g
C	Na_2SO_4	80°C	20g
D	NaNO_3	25°C	10g

19. Which of the following predictions is **WRONG** about the solubility of substance X in substance Y?

	Substance X	Substance Y	Solubility
A	Methane	Petrol	Soluble
B	NaCl	Water	Soluble
C	Grease	Water	Insoluble
D	Paint	Kerosene oil	Insoluble

20. Which substance is reduced in the given reaction?

- Iron
- Copper
- Sulphur
- Oxygen

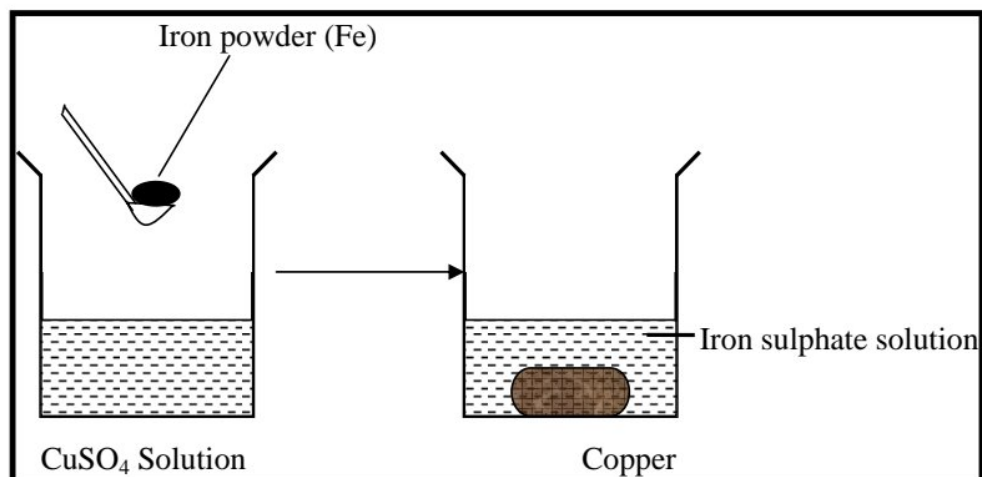

21. Which of the following is the oxidation state of phosphorus in H_3PO_4 ?
- +2
 - +3
 - +4
 - +5

PLEASE TURN OVER THE PAGE

22. Which of the following should be added during chromium plating to prevent hydrolysis?

- A. Antimonial lead
- B. Chromium sulphate
- C. Sulphuric acid
- D. Sodium hydroxide

23. When Cl_2 is bubbled in the KI solution test tube, the solution turns reddish brown due to the liberation of

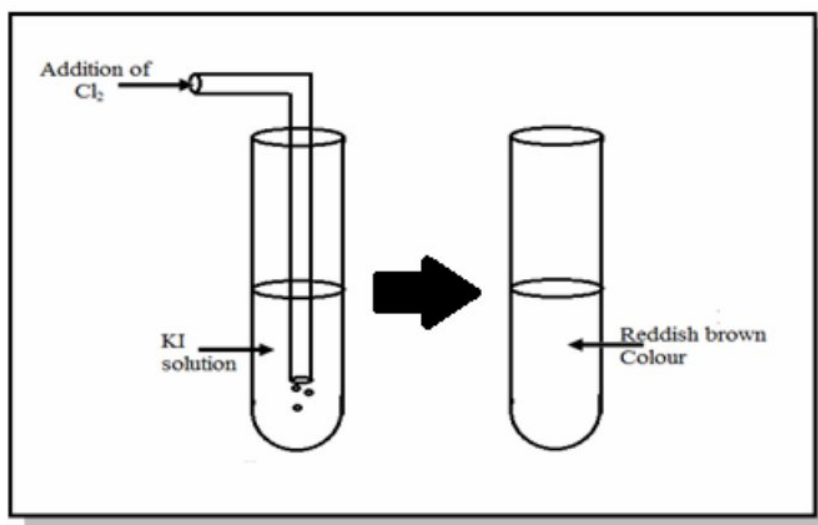

- A. iodine.
- B. potassium.
- C. potassium chloride.
- D. potassium iodide.

24. Which of the following is formed when a metal reacts with oxygen?

- A. Hydroxides
- B. Basic oxide
- C. Acidic oxide
- D. Neutral oxide

25. Which of the following reacts vigorously with dilute acids to produce hydrogen gas and salt?

- A. Calcium
- B. Copper
- C. Silver
- D. Zinc

AGA KHAN UNIVERSITY EXAMINATION BOARD

SECONDARY SCHOOL CERTIFICATE

CLASS IX EXAMINATION

MAY 2012

Chemistry Paper I

Time allowed: 35 minutes Marks 25

INSTRUCTIONS

1. Read each question carefully.
2. Answer the questions on the separate answer sheet provided. DO NOT write your answers on the question paper.
3. There are 100 answer numbers on the answer sheet. Use answer numbers 1 to 25 only.
4. In each question there are four choices A, B, C, D. Choose ONE. On the answer grid black out the circle for your choice with a pencil as shown below.

Correct Way	Incorrect Ways
1 (A) (B) ● (D)	1 (A) (B) (C) (D)
	2 (A) (B) (C) (D)
	3 (A) (B) (C) (D)
	4 (A) (B) (C) (D)

Candidate's Signature

5. If you want to change your answer, ERASE the first answer completely with a rubber, before blacking out a new circle.
6. DO NOT write anything in the answer grid. The computer only records what is in the circles.
7. You may use a simple calculator if you wish.

1. A student has to identify the element, mixture and compound in the given substances.

i. Mercury	ii. Glucose	iii. Ammonia	iv. Brass
------------	-------------	--------------	-----------

Which of the following arrangements is correct for the given substances?

	i	ii	iii	iv
A.	Element	Compound	Mixture	Element
B.	Element	Compound	Compound	Mixture
C.	Compound	Element	Mixture	Compound
D.	Compound	Mixture	Mixture	Element

2. Which of the following represents the formula mass of ammonium ion?
- A. 15
B. 16
C. 17
D. 18
3. Which type of chemical reaction occurs when zinc metal reacts with dilute sulphuric acid?
- A. Addition reaction
B. Displacement reaction
C. Decomposition reaction
D. Double displacement reaction
4. All of the following conclusions are drawn by Rutherford on the experiment of scattering alpha particles EXCEPT that
- A. the space inside the atom is hollow.
B. the central part of atom is positively charged.
C. the electrons are distributed in space around nucleus.
D. the electrons jump to higher energy level by absorbing energy.
5. If an atom has 17 electrons, then its outermost shell will be
- A. K.
B. L.
C. M.
D. N.
6. Which of the following elements represents the electronic structure of the ion shown in the given diagram?

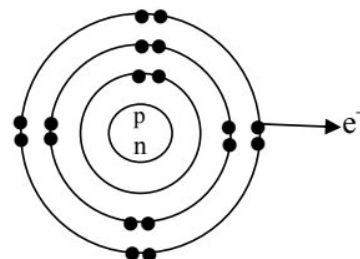

Electronic Structure of an ion X^{+1}

7. Which of the following characteristics is/are correct for an isotope?
- I. Similar electronic structures
 - II. Similar chemical properties
 - III. Similar mass number
- A. I only
 - B. I and II only
 - C. II only
 - D. II and III only
8. Which of the following elements has the largest atomic radius?
- A. Cs
 - B. Li
 - C. Fr
 - D. Rb
9. The elements having 3 shells and $5e^-$ in their outermost shell belong to group
- A. II A.
 - B. III A.
 - C. IV A.
 - D. V A.
10. All of the following periodic trends increase as we move from left to right in a period, EXCEPT
- A. atomic radii.
 - B. electronegativity.
 - C. electron affinity.
 - D. ionization energy.
11. Which of the following types of bond is formed when a metal reacts with a non-metal?
- A. Ionic
 - B. Metallic
 - C. Covalent
 - D. Coordinate covalent
12. Which type of covalent bonding is formed when two atoms of nitrogen react with each other?

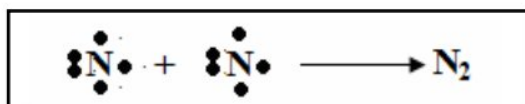

- A. Single
- B. Double
- C. Triple
- D. Coordinate

PLEASE TURN OVER THE PAGE

13. In the given reaction, H^+ acts as a/an

- A. neutral species.
- B. acceptor.
- C. carrier.
- D. donor.

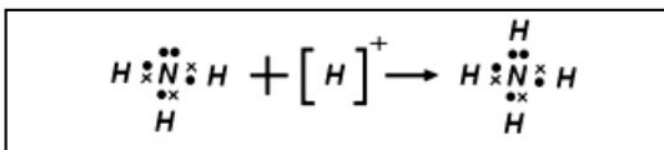

14. The diagram given below represents the movement and distribution of particles in different states of matter.

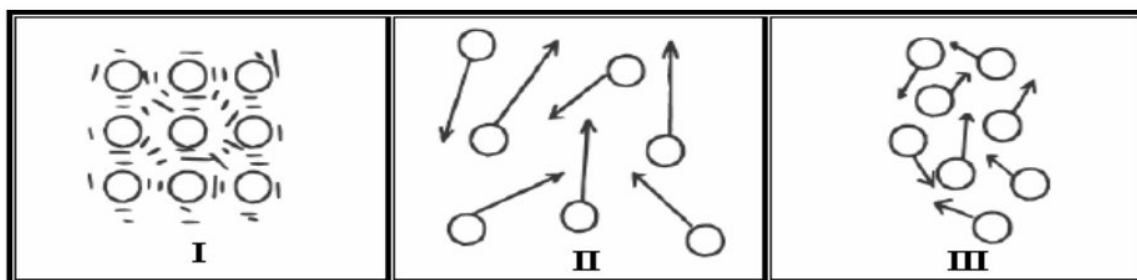

Which of the following arrangements is correct for the given diagram?

	I	II	III
A.	Solid	Liquid	Gas
B.	Liquid	Solid	Gas
C.	Solid	Gas	Liquid
D.	Liquid	Gas	Solid

15. Which of the following processes involves the increase of kinetic energy of molecules of a liquid by heating?

- A. Condensation
- B. Evaporation
- C. Sublimation
- D. Melting

16. Which of the following is an example of diffusion?

- A. Bubbles rising in a beaker of boiling water
- B. Fragrance of flowers in a garden
- C. Swelling of raisins in water
- D. Steam condensing on a cold window

17. A teaspoon of coffee granules dissolves when mixed in a cup of hot water. This process produces a coffee solution. The original granules are classified as a

- A. product.
- B. reactant.
- C. solvent.
- D. solute.

18. Which of these action(s) will cause more sugar to dissolve in a saturated solution?
- Add more sugar while stirring.
 - Heat the solution while adding more sugar.
 - Grind the sugar to a powder; then add while stirring.
- II only
 - I and II only
 - III only
 - II and III only
19. A teacher prepared 0.125 M sodium chloride stock solution. What volume of the stock solution is required to prepare a dilution of 0.05 M in 100 ml?
- 100 ml
 - 60 ml
 - 40 ml
 - 20 ml
20. Which of the following test tubes shows favourable conditions for corrosion?

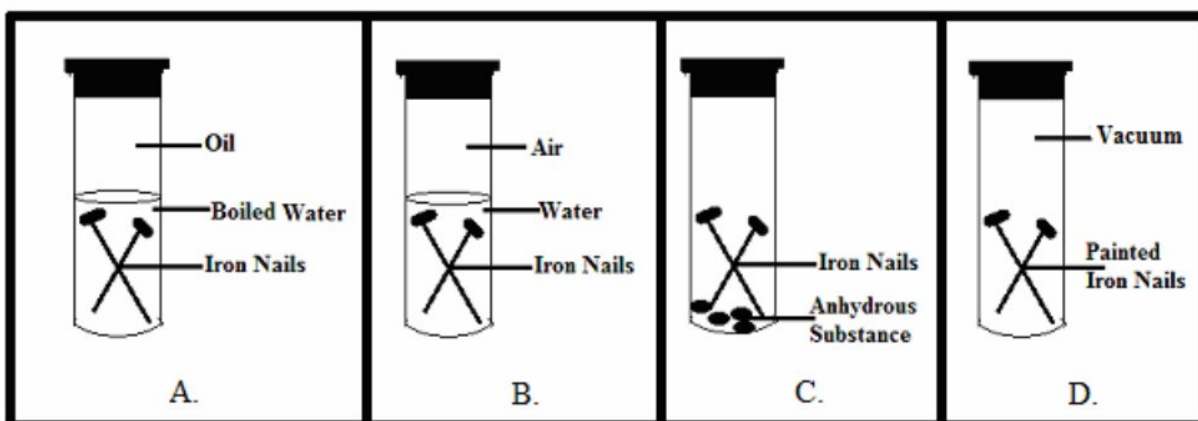

21. A laboratory assistant arranges a set of solutions.
- Which of the following is an example of a strong electrolyte?

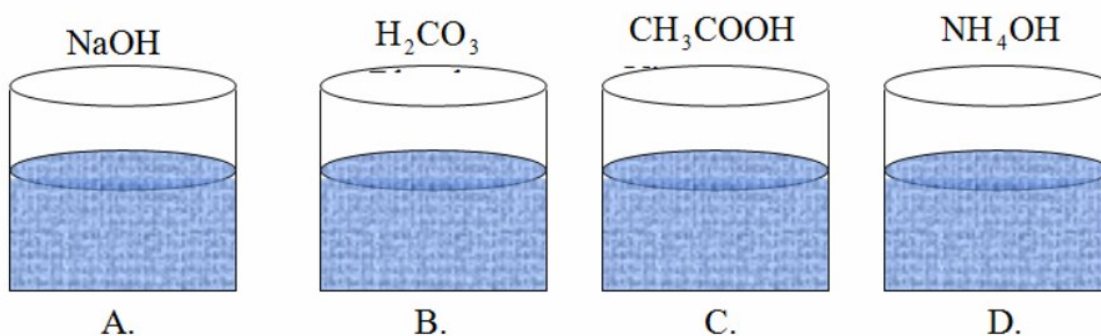

PLEASE TURN OVER THE PAGE

22. Which of the following products is obtained in the given word equation?



- A. Metal ion
- B. Metal oxide
- C. Metal hydroxide
- D. Metal oxide + Hydrogen

23. Which of the following metals reacts explosively with dilute acids?

- A. Zinc
- B. Silver
- C. Copper
- D. Calcium

24. Which of the following metals does NOT occur in free state in nature?

- A. Copper
- B. Gold
- C. Silver
- D. Sodium

25. A student put some calcium tablets in a glass of water. He observed that the tablets sank and reacted vigorously with water.

Which of the following products are formed in the above reaction?

- A. $\text{Ca(OH)}_2 + \text{H}_2$
- B. $\text{Ca(OH)}_2 + \text{H}_2\text{O}$
- C. $\text{CaO} + \text{H}_2$
- D. $\text{CaO} + \text{H}_2\text{O}$

AGA KHAN UNIVERSITY EXAMINATION BOARD

SECONDARY SCHOOL CERTIFICATE

CLASS IX EXAMINATION

MAY 2013

Chemistry Paper I

Time: 35 minutes Marks: 25

INSTRUCTIONS

1. Read each question carefully.
2. Answer the questions on the separate answer sheet provided. DO NOT write your answers on the question paper.
3. There are 100 answer numbers on the answer sheet. Use answer numbers 1 to 25 only.
4. In each question there are four choices A, B, C, D. Choose ONE. On the answer grid black out the circle for your choice with a pencil as shown below.

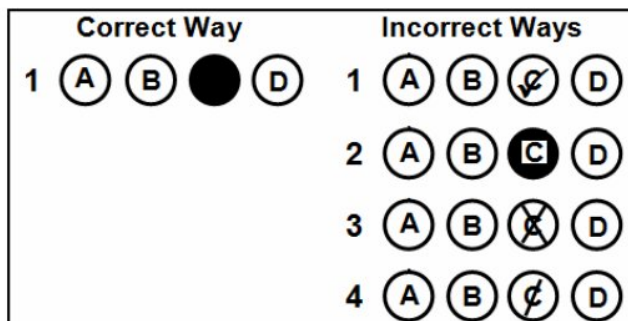

Candidate's Signature

5. If you want to change your answer, ERASE the first answer completely with a rubber, before blacking out a new circle.
6. DO NOT write anything in the answer grid. The computer only records what is in the circles.
7. You may use a simple calculator if you wish.

1. A physiologist took a blood sample from a diabetic patient and examined the composition and amount of each component present in the sample using different techniques and instruments.

His study is related to the field of

- A. nuclear chemistry.
 B. physical chemistry.
 C. inorganic chemistry.
 D. analytical chemistry.
2. The empirical formula of a compound is CH_2O and its molecular mass is 90. What will be its molecular formula?

- A. CH_2O
 B. $\text{C}_2\text{H}_4\text{O}_2$
 C. $\text{C}_3\text{H}_6\text{O}_3$
 D. $\text{C}_4\text{H}_8\text{O}_4$

3. Which of the following is an example of a displacement reaction?

- A. $\text{Cl}_{2(\text{g})} + 2\text{NaBr}_{(\text{aq})} \rightarrow 2\text{NaCl}_{(\text{aq})} + \text{Br}_{2(\text{g})}$
 B. $\text{H}_2\text{SO}_{4(\text{aq})} + 2\text{LiOH}_{(\text{aq})} \rightarrow \text{Li}_2\text{SO}_{4(\text{aq})} + 2\text{H}_2\text{O}_{(\text{l})}$
 C. $\text{CH}_{4(\text{g})} + 2\text{O}_{2(\text{g})} \rightarrow \text{CO}_{2(\text{g})} + 2\text{H}_2\text{O}_{(\text{l})}$
 D. $2\text{KClO}_{3(\text{s})} \rightarrow 2\text{KCl}_{(\text{s})} + 3\text{O}_{2(\text{g})}$

4. How many protons are there in an aluminium ion (Al^{3+})?

- A. 11
 B. 12
 C. 13
 D. 14

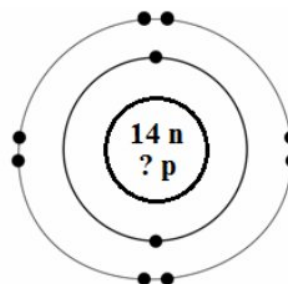

Structure of Aluminium Ion

5. In Rutherford's gold foil experiment, the complete re-bouncing of alpha particles showed that the nucleus of an atom is

- A. hard and dense.
 B. dense and hollow.
 C. hard and negative.
 D. small and neutral.

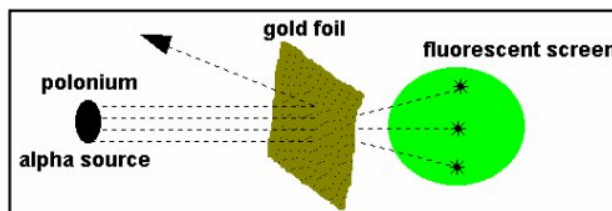

6. Which of the following electronic configurations represents an element of group IA?

- A. $1s^2, 2s^2, 2p^5$
 B. $1s^2, 2s^2, 2p^6$
 C. $1s^2, 2s^2, 2p^6, 3s^1$
 D. $1s^2, 2s^2, 2p^6, 3s^2, 3p^4$

7. Which of the following pairs of molecules has double covalent bonds in their structures?
- A. O_2 and HCl
 - B. NH_3 and N_2
 - C. H_2O and C_2H_2
 - D. CO_2 and C_2H_4

8. Which of the following compounds shows hydrogen bonding?
- A. H_2S
 - B. CH_3OH
 - C. C_6H_6
 - D. CH_3Cl

9. Which of the following ionic compounds is represented by the given dot and cross structure?

- A. Na_2O
- B. K_2O
- C. $CaCl_2$
- D. $MgCl_2$

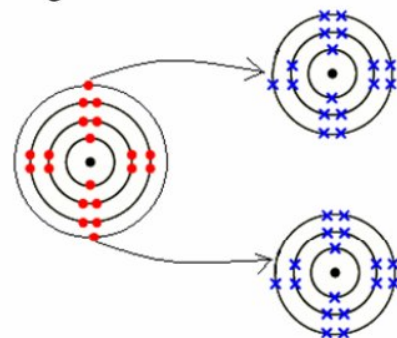

10. An anion (X^{2-}) has an atomic mass 32 and a total of 18 electrons. To which period and group will the element belong?

	Period	Group
A	6	III
B	3	VI
C	2	IV
D	4	II

11. An element belonging to group VI of the periodic table will form an ion

- A. X^{+6}
- B. X^{-6}
- C. X^{2+}
- D. X^{2-}

12. Cesium ($Z = 55$) loses electrons more readily than potassium ($Z = 19$). This is because of greater
- shielding effect.
 - ionization energy.
 - electronegativity.
 - electron affinity.

13. Which of the following gases will diffuse most rapidly if the lid is removed?
 [Hint: Atomic masses for Br = 80 amu, N = 14 amu, O = 16 amu, C = 12 amu and H = 1 amu]

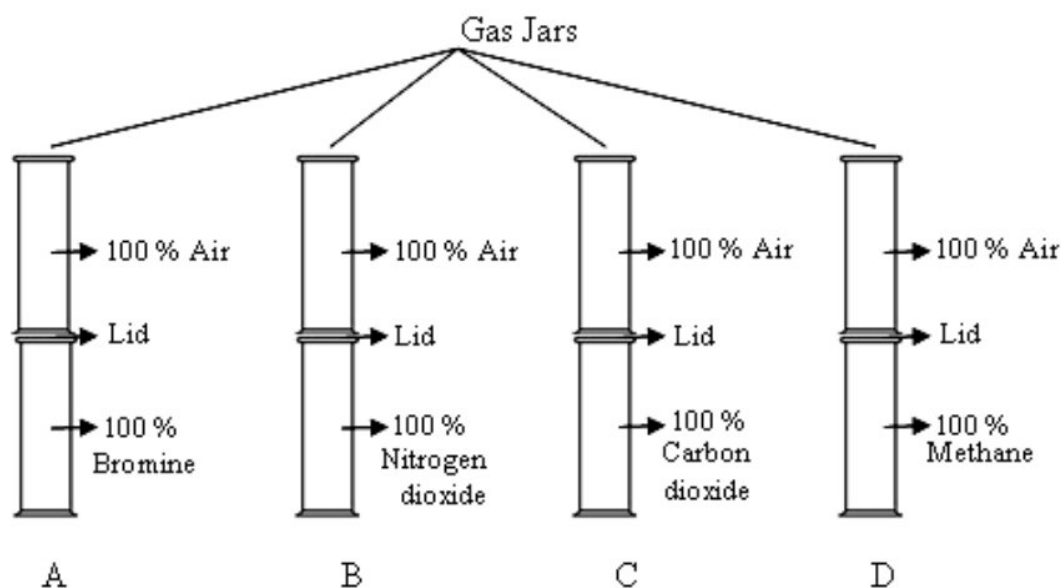

14. If you put a drop of ethanol on a watch glass, what happens to the drop after a while?
- The drop of ethanol will
- freeze.
 - evaporate.
 - condense.
 - diffuse.

15. The given graph shows the freezing point of water.
 What is the state of water between X and Y?

- Solid
- Liquid
- Liquid + Solid
- Solid + Gas

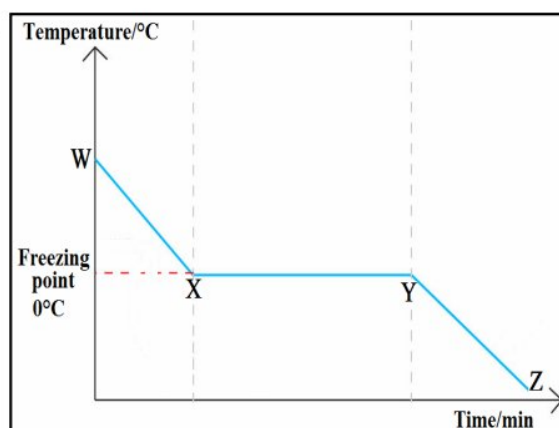

16. Two persons went to a shop and asked for fizzy drinks. They were offered two bottles, one chilled and the other warm. The chilled fizzy drink tasted better than the other. What could be the reason?
- Less carbon dioxide is lost at higher temperature.
 - Less carbon dioxide is lost at lower temperature.
 - More carbon dioxide is lost at higher pressure.
 - Less carbon dioxide is lost at lower pressure.

17. Which of the following types of solution will be formed by the smoke of a cigarette in air?

- A gas into gas
- A gas into solid
- A solid into gas
- A liquid into gas

18. How much volume of solution P is used for making solution Q?

- 0.04 cm^3
- 40 cm^3
- 250 cm^3
- 200 cm^3

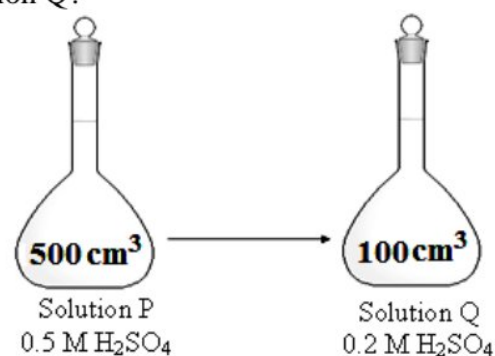

19. Which of the following is an oxidizing agent in the given redox reaction?

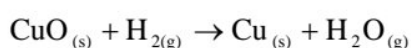

- CuO
 - H_2
 - Cu
 - H_2O
20. Which of the following represents the correct oxidation states of carbon in the given compounds?

	CO	CO_2	H_2CO_3
A	0	+2	+1
B	+1	+2	+1
C	+2	+4	+1
D	+2	+4	+4

PLEASE TURN OVER THE PAGE

21. Which of the following statements about rusting of iron is FALSE?

- A. Its formula is $\text{Fe}_2\text{O}_3 \cdot n\text{H}_2\text{O}$.
- B. It is a redox chemical reaction.
- C. It is accelerated in the presence of acidic medium.
- D. It occurs in the presence of distilled deoxygenated water.

22. Which of the following characteristics of calcium makes it more reactive than magnesium?

	Ionization Energy	Effective Nuclear Charge
A	Low	High
B	Low	Low
C	High	Low
D	High	High

23. All of the following properties of gold make it useful for making a space craft EXCEPT it is

- A. the most reactive metal.
- B. able to reflect light.
- C. malleable and ductile.
- D. resistant to corrosion.

24. Which of the following is an alkaline earth metal?

- A. Sodium
- B. Radium
- C. Rubidium
- D. Cesium

25. Sodium metal is kept under paraffin oil because it

- A. is soft.
- B. has low density.
- C. has low melting point.
- D. is highly electropositive.

AGA KHAN UNIVERSITY EXAMINATION BOARD

SECONDARY SCHOOL CERTIFICATE

CLASS IX EXAMINATION

MAY 2014

Chemistry Paper I

Time: 35 minutes Marks: 25

INSTRUCTIONS

1. Read each question carefully.
2. Answer the questions on the separate answer sheet provided. DO NOT write your answers on the question paper.
3. There are 100 answer numbers on the answer sheet. Use answer numbers 1 to 25 only.
4. In each question there are four choices A, B, C, D. Choose ONE. On the answer grid black out the circle for your choice with a pencil as shown below.

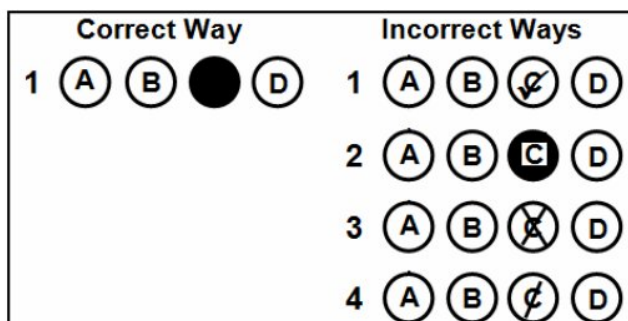

Candidate's Signature

5. If you want to change your answer, ERASE the first answer completely with a rubber, before blacking out a new circle.
6. DO NOT write anything in the answer grid. The computer only records what is in the circles.
7. You may use a simple calculator if you wish.

1. The formula mass of glucose ($C_6H_{12}O_6$) is
 - A. 80 amu.
 - B. 100 amu.
 - C. 180 amu.
 - D. 280 amu.
2. In biochemistry, students study about chemical reactions of substances that take place in
 - A. the manufacturing of goods.
 - B. the body of living organisms.
 - C. different parts of the vehicles.
 - D. the generation of electrical power.
3. The given equation shows the homolytic breakage of bond between chlorine atoms in the presence of light.

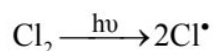

The product (Cl^\bullet) formed is a/an

- A. atom.
 - B. molecule.
 - C. free radical.
 - D. molecular ion.
4. All of the following conclusions are drawn by Rutherford based on the experiment of scattering alpha particles EXCEPT that
 - A. the space inside the atom is hollow.
 - B. the central part of atom is positively charged.
 - C. the electrons are distributed in space around a nucleus.
 - D. the electrons jump to higher energy level by absorbing energy.
 5. Which of the following represents the number of sub-atomic particles in carbon – 14 (^{14}C)?

	Proton	Neutron	Electron
A.	6	6	6
B.	6	7	7
C.	6	8	6
D.	8	6	6

6. Which of the following shows the electronic configuration of a boron atom (${}_{5}^{11}\text{B}$)?

- A. $1s^2, 2s^2, 2p^1$
- B. $1s^2, 2s^2, 2p^2$
- C. $1s^2, 2s^2, 2p^6$
- D. $1s^2, 2s^2, 2p^6, 3s^1$

7. Which of the following types of bonding exists in the given molecule?

- A. Ionic
- B. Metallic
- C. Covalent
- D. Coordinate covalent



8. All of the following elements on ionization form a cation EXCEPT

- A. silver.
- B. lithium.
- C. oxygen.
- D. calcium.

9. When ammonia (NH_3) reacts with hydrogen ion (H^+), it forms ammonium ion (NH_4^+). A coordinate covalent bond is formed in ammonium ion because

- A. nitrogen gains and hydrogen loses electrons.
- B. nitrogen attains stability by gaining electrons.
- C. nitrogen and hydrogen mutually share an electron pair.
- D. nitrogen provides a lone pair of electrons to hydrogen ion.

10. Which of the following elements exists as a diatomic molecule?

- A. Neon
- B. Sodium
- C. Lithium
- D. Chlorine

11. The given table shows elements of the halogen family. What happens to electron affinity and shielding effect when we move down the group?

	Electron Affinity	Shielding Effect
A.	Decreases	Increases
B.	Increases	Decreases
C.	Decreases	Decreases
D.	Increases	Increases

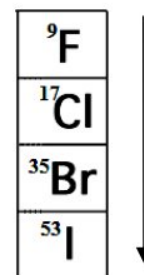

PLEASE TURN OVER THE PAGE

12. Which of the following represents the d-block elements in the given sketch of the periodic table?

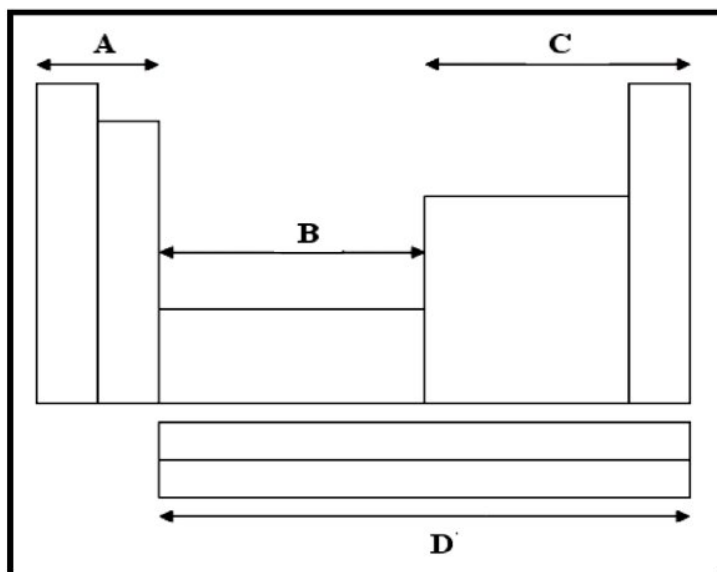



13. Which of the following matter is **WRONGLY** matched with its property?

	Matter	Property of Particles
A.	Balloon	Can effuse
B.	Table	Can be compressed
C.	Water	Has a definite volume
D.	Smoke	Has weak intermolecular forces

14. Which of the following factors decreases the boiling point of a liquid?

- A. Stronger intermolecular forces
- B. Lower external pressure
- C. Lower vapour pressure
- D. Stronger polarity

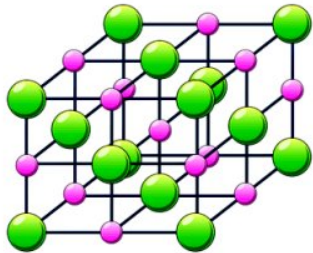
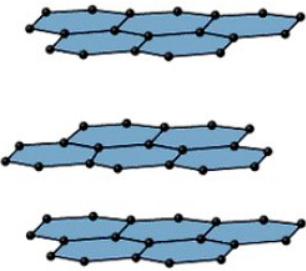
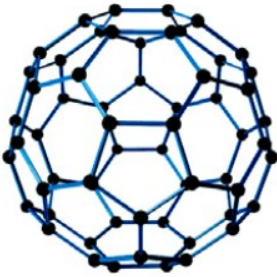
15. Diamond is an allotropic form of carbon. Which of the following shows the structure of diamond?

	
A.	B.
	
C.	D.

16. Which of the following information shows that the solution is supersaturated?

Type of Solution	Compound	Temperature	Mass of Solute in 100ml of Water
A.	NH ₃	90°C	10g
B.	NH ₄ Cl	80°C	70g
C.	Na ₂ SO ₄	80°C	20g
D.	NaNO ₃	25°C	10g

17. Which of the following is NOT an example of a solution made up of liquid into solid?

- A. Alloys
- B. Butter
- C. Cheese
- D. Amalgam

18. All of the following substances can dissolve in water EXCEPT

- A. salt.
- B. sugar.
- C. grease.
- D. ethanol.

PLEASE TURN OVER THE PAGE

19. Which of the following is the reducing agent in the given reaction?

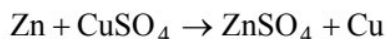

- A. Zn
B. Cu
C. CuSO_4
D. ZnSO_4
20. All of the following factors speed up the process of corrosion in iron EXCEPT
- A. acidic medium.
B. sunlight.
C. oxygen.
D. water.
21. Galvanizing is a method used to prevent the corrosion of iron. This method basically involves the coating of iron with
- A. tin.
B. zinc.
C. copper.
D. chromium.
22. Which of the following elements on reaction with oxygen forms a basic oxide?
- A. Phosphorus
B. Sulphur
C. Sodium
D. Silicon
23. Platinum alloyed with palladium and rhodium is used
- A. in photographic films.
B. in the making of coins.
C. as a catalyst in automobiles.
D. as a coolant in nuclear reactors.
24. Gold is a noble metal due to which it is NOT
- A. ductile.
B. malleable.
C. affected by atmosphere.
D. alloyed with other metals.
25. What products are formed when sodium metal reacts with water?
- A. Sodium hydride and oxygen gas
B. Sodium oxide and hydrogen gas
C. Sodium hydroxide and oxygen gas
D. Sodium hydroxide and hydrogen gas

END OF PAPER

AGA KHAN UNIVERSITY EXAMINATION BOARD

SECONDARY SCHOOL CERTIFICATE

CLASS IX EXAMINATION

MAY 2015

Chemistry Paper I

Time: 35 minutes Marks: 25

INSTRUCTIONS

1. Read each question carefully.
2. Answer the questions on the separate answer sheet provided. DO NOT write your answers on the question paper.
3. There are 100 answer numbers on the answer sheet. Use answer numbers 1 to 25 only.
4. In each question there are four choices A, B, C, D. Choose ONE. On the answer grid black out the circle for your choice with a pencil as shown below.

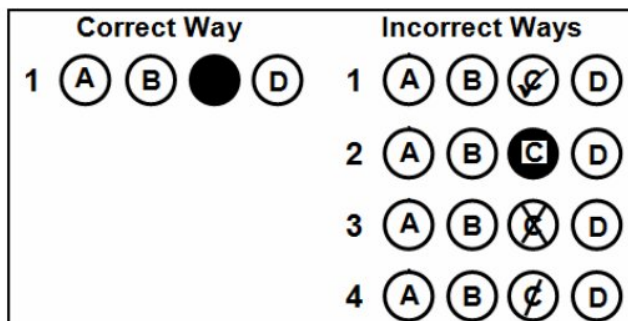

Candidate's Signature

5. If you want to change your answer, ERASE the first answer completely with a rubber, before blacking out a new circle.
6. DO NOT write anything in the answer grid. The computer only records what is in the circles.
7. You may use a simple calculator if you wish.

1. If the empirical formula of a compound is CH_2O and its molecular mass is 90, what will be its molecular formula?

- A. CH_2O
- B. $\text{C}_2\text{H}_4\text{O}_2$
- C. $\text{C}_3\text{H}_6\text{O}_3$
- D. $\text{C}_4\text{H}_8\text{O}_4$

2. Methane undergoes chlorination explosively in the presence of bright sunlight. The equation for the reaction is given below.

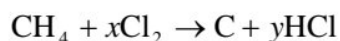

In the above reaction, what are the values of x and y ?

- A. $x = 2, y = 4$
- B. $x = 2, y = 2$
- C. $x = 4, y = 4$
- D. $x = 4, y = 2$

3. Assume that X is the symbol of group IA element and Y is the symbol of group VIA element.

When X reacts with Y, it will form a compound with the formula

- A. XY
- B. X_2Y
- C. XY_2
- D. X_6Y

4. Which of the following is the electronic configuration of a calcium ion (${}^{40}_{20}\text{Ca}^{2+}$)?

- A. $1s^2 2s^2 2p^6 3s^2 3p^6 4s^2$
- B. $1s^2 2s^2 2p^6 3s^2 3p^6 4s^1$
- C. $1s^2 2s^2 2p^6 3s^2 3p^6$
- D. $1s^2 2s^2 2p^6 3s^2$

5. In Rutherford's gold foil experiment, the complete re-bouncing of alpha particles showed that the nucleus of an atom is

- A. large.
- B. small.
- C. negatively charged.
- D. positively charged.

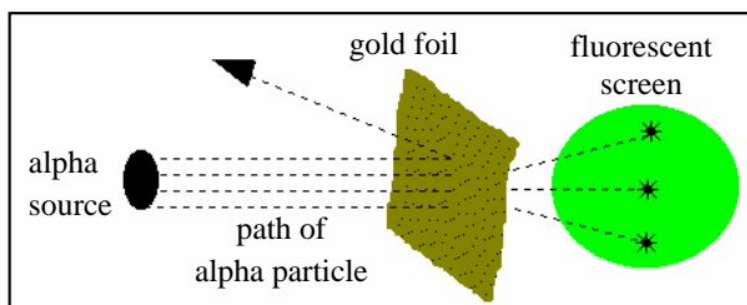

6. Which diagram represents the nucleus of an atom with atomic mass 5 and atomic number 2?
[NOTE: ○ = protons and ● = neutrons]

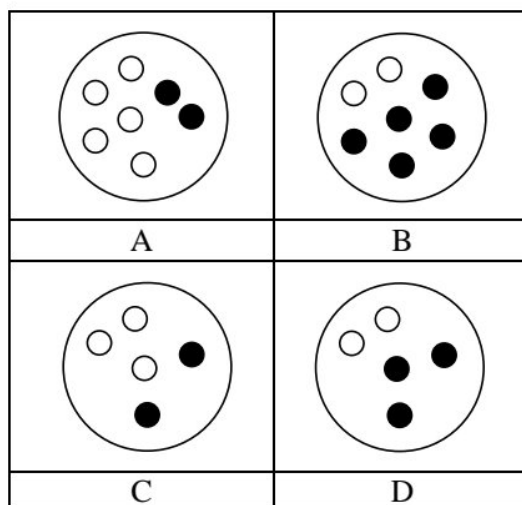

7. Which force of attraction is represented by the dotted lines between the molecules of the given compound?

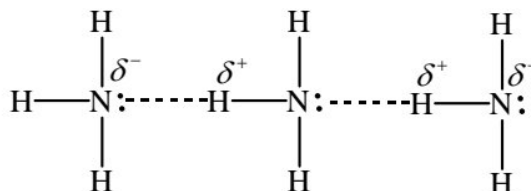

- A. Hydrogen bonding
 B. Covalent bonding
 C. Dipole-dipole interaction
 D. Co-ordinate covalent bonding
8. In a molecule of ethyne, how many electron pairs are involved in the bonding between carbon-carbon atoms?
- A. 2
 B. 3
 C. 4
 D. 6
9. In which of the following pairs do both compounds have ionic bonding?
- A. H_2 and O_2
 B. CaF_2 and KI
 C. HCl and H_2O
 D. $\text{C}_6\text{H}_{12}\text{O}_6$ and CH_4

PLEASE TURN OVER THE PAGE

10. Given below is the period 3 of the modern periodic table.

Na Sodium	Mg Magnesium	Al Aluminium	Si Silicon	P Phosphorus	S Sulphur	Cl Chlorine	Ar Argon
---------------------	------------------------	------------------------	----------------------	------------------------	---------------------	-----------------------	--------------------

Which of the following elements will have the highest electronegativity?

- A. Argon
 - B. Silicon
 - C. Chlorine
 - D. Magnesium
11. Phosphorus ($^{31}_{15}\text{P}$) will have similar chemical properties to that of an element with the atomic number
- A. 8
 - B. 7
 - C. 5
 - D. 3

12. The given ion is formed from an element belonging to which group in the modern periodic table?

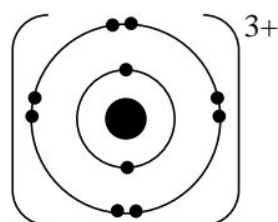

- A. IIA
- B. IIIA
- C. VA
- D. VIIIA

13. In the given diagram, which of the following represents the process of evaporation?

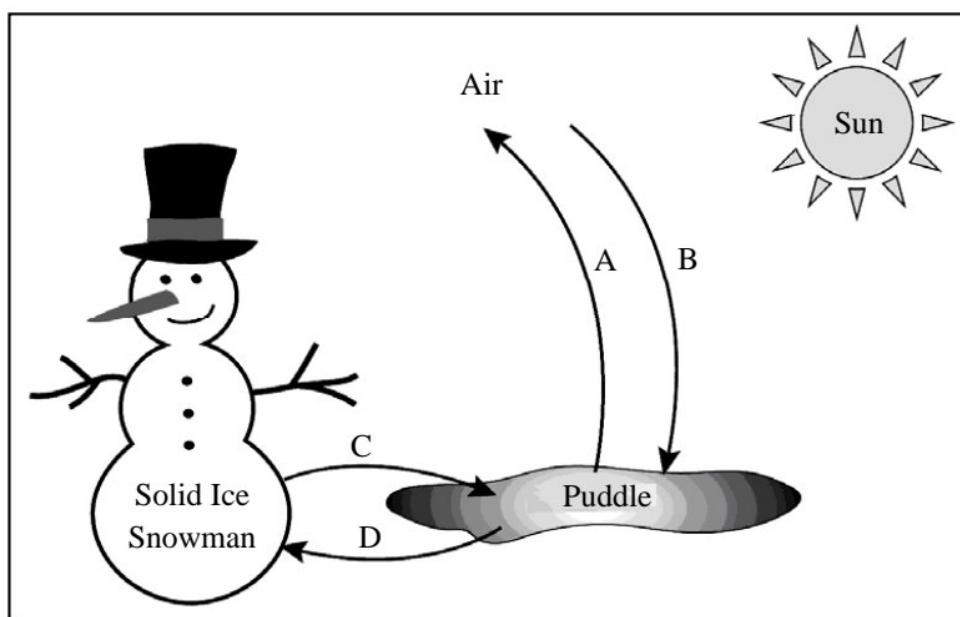

14. Which of the following statements about the behaviour of gases is FALSE?
- A. Gases are easily compressed.
 - B. Gases occupy all available space.
 - C. Gas particles possess orderly arrangement.
 - D. Gas particles possess very high kinetic energy.
15. Under the same conditions of temperature and pressure, which of the following molecules of gases will diffuse the fastest through air? [NOTE: Atomic mass of O = 16 amu, Cl = 35.5 amu, N = 14 amu, C = 12 amu and H = 1 amu]
- A. O₂
 - B. Cl₂
 - C. NO₂
 - D. CH₄
16. A teacher asks a student to dissolve 2.5 g of sodium carbonate in 50 g of water. What will be the concentration of the prepared solution?
- A. 4.76%
 - B. 5.00%
 - C. 47.6%
 - D. 95.2%
17. A scientist prepares 0.125 M sodium chloride stock solution. What volume of the stock solution is required to prepare a 100 mL dilute solution of 0.05 M?
- A. 20 mL
 - B. 40 mL
 - C. 60 mL
 - D. 100 mL
18. Which of the following statements defines a solution?
- A. A pure compound having one or more solutes dissolved in a solvent
 - B. A heterogeneous mixture having one or more solutes dissolved in a solvent
 - C. A homogeneous mixture having one or more solutes dissolved in a solvent
 - D. A pure compound having a solute and a solvent mixed in a fixed ratio by mass
19. All of the following are measures for the protection of an iron rod against rusting EXCEPT
- A. alloying iron with other metals.
 - B. exposing the iron rod to moist air.
 - C. greasing the surface of the iron rod.
 - D. painting the surface of the iron rod.

PLEASE TURN OVER THE PAGE

20. Which of the following conducts electricity?
- Cooking oil
 - Molten sugar
 - Ethyl alcohol
 - Hydrochloric acid
21. Which of the following statements is TRUE for an electrolytic cell?
- It converts chemical energy into electrical energy.
 - It consists of two half cells with different electrolytes.
 - It uses current to carry out a non-spontaneous chemical reaction.
 - It uses a salt bridge to provide a pathway for the migration of ions.
22. Which of the following statements is FALSE for soft metals?
- They are easy to break.
 - They have low binding energies.
 - They belong to d-block of the periodic table.
 - They have less delocalized electrons than hard metals.
23. The first and second ionization energies of two elements, **X** and **Y**, are given in the table below.

Element	I.E. ₁ (kJ mol ⁻¹)	I.E. ₂ (kJ mol ⁻¹)
X	737	1450
Y	496	4563

On the basis of the given data, **X** and **Y** could be

	X	Y
A	Mg	Na
B	Na	Mg
C	Na	K
D	K	Na

24. Which of the following reactions of a halogen with the salt of an alkali metal is CORRECT?
- $2\text{KI} + \text{Cl}_2 \rightarrow 2\text{KCl} + \text{I}_2$
 - $2\text{KBr} + \text{I}_2 \rightarrow 2\text{KI} + \text{Br}_2$
 - $2\text{KCl} + \text{I}_2 \rightarrow 2\text{KI} + \text{Cl}_2$
 - $2\text{KCl} + \text{Br}_2 \rightarrow 2\text{KBr} + \text{Cl}_2$
25. Which of the following reacts the most vigorously with dilute acids to produce hydrogen gas and salt?
- Zinc
 - Silver
 - Copper
 - Calcium

AGA KHAN UNIVERSITY EXAMINATION BOARD

SECONDARY SCHOOL CERTIFICATE

CLASS IX EXAMINATION

MAY 2016

Chemistry Paper I

Time: 35 minutes Marks: 25

INSTRUCTIONS

1. Read each question carefully.
2. Answer the questions on the separate answer sheet provided. DO NOT write your answers on the question paper.
3. There are 100 answer numbers on the answer sheet. Use answer numbers 1 to 25 only.
4. In each question there are four choices A, B, C, D. Choose ONE. On the answer grid black out the circle for your choice with a pencil as shown below.

Correct Way	Incorrect Ways
1 (A) (B) ● (D)	1 (A) (B) (C) (D)
	2 (A) (B) (C) (D)
	3 (A) (B) (C) (D)
	4 (A) (B) (C) (D)

Candidate's Signature

5. If you want to change your answer, ERASE the first answer completely with a rubber, before blacking out a new circle.
6. DO NOT write anything in the answer grid. The computer only records what is in the circles.
7. You may use a simple calculator if you wish.

1.

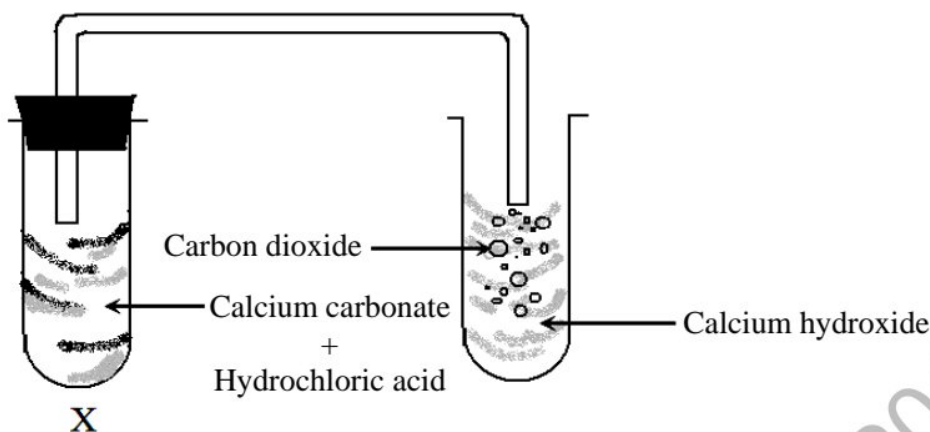

The word equation that CORRECTLY represents the chemical reaction taking place in test tube X is

- A. calcium carbonate + hydrochloric acid \rightarrow carbon dioxide + calcium chloride
 B. calcium carbonate + hydrochloric acid \rightarrow carbon dioxide + calcium hydroxide
 C. calcium carbonate + hydrochloric acid \rightarrow carbon dioxide + water + calcium chloride
 D. calcium carbonate + hydrochloric acid \rightarrow carbon dioxide + water + calcium hydroxide
2. A physiologist took a blood sample from a diabetic patient and examined the composition and amount of each component present in the sample using different techniques and instruments.
- His study is related to the field of
- A. nuclear chemistry.
 B. physical chemistry.
 C. inorganic chemistry.
 D. analytical chemistry.
3. A compound X has an empirical formula C_3H_3O and its molecular mass is 110.
- Which of the following represents the molecular formula of compound X?
- A. CHO
 B. $C_3H_3O_3$
 C. $C_6H_6O_2$
 D. C_6H_6O
4. The electronic configuration of aluminium ion in aluminium oxide, Al_2O_3 , is
- (Note: ${}_{13}^{27}Al$)
- A. $1s^2 2s^2 2p^6$
 B. $1s^2 2s^2 2p^6 3s^1$
 C. $1s^2 2s^2 2p^6 3s^2 3p^1$
 D. $1s^2 2s^2 2p^6 3s^2 3p^2$

5. Which of the following statements is TRUE about Bohr's atomic model?
- A. It shows that an atom produces continuous spectrum.
 - B. It proves that the plum-pudding model of an atom was correct.
 - C. It proves that the size and energy of each orbit in an atom is quantised.
 - D. It shows that electrons emit radiation when revolving around the nucleus.
6. How many sub-shells are present in an L-shell?
- A. 1
 - B. 2
 - C. 3
 - D. 4
7. Which of the following two elements react to form a covalent bond?
- A. Ba and Cl
 - B. K and O
 - C. H and S
 - D. Na and F

8.

I.	${}^{19}_{9}\text{F}$	III.	${}^9_4\text{Be}$	V.	${}^{32}_{16}\text{S}$
II.	${}^{40}_{18}\text{Ar}$	IV.	${}^{27}_{13}\text{Al}$	VI.	${}^{14}_7\text{N}$

Which of the above mentioned elements form cations?

- A. I and VI
 - B. III and IV
 - C. I, V and VI
 - D. II, III and IV
9. Which of the following compounds shows hydrogen bonding?
- A. H_2S
 - B. C_6H_6
 - C. CH_3Cl
 - D. CH_3OH
10. In the modern periodic table, the elements are arranged according to
- A. increasing atomic mass.
 - B. decreasing atomic mass.
 - C. increasing atomic number.
 - D. decreasing atomic number.

PLEASE TURN OVER THE PAGE

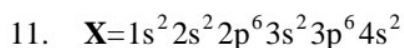

According to the given electronic configuration, the element X belongs to which group and period of the modern periodic table?

	Period	Group
A	2	IVA
B	3	VIIIA
C	4	IIA
D	7	VIIIA

12. An oxygen atom is similar to an atom of sulphur because they both
- A. form diatomic molecules.
 - B. have the same number of protons.
 - C. form cations with a double negative charge.
 - D. have the same number of valence electrons.
13. At constant temperature, if the volume of a gas in a container is reduced to half, then the pressure on the gas will
- A. be doubled.
 - B. reduce to half.
 - C. remain the same.
 - D. reduce to a quarter.
14. Liquids can be converted into solids by
- A. increasing collision among the molecules.
 - B. decreasing kinetic energy of the molecules.
 - C. increasing volume occupied by the molecules.
 - D. decreasing force of attraction among the molecules.
15. The picture shows gas formation around snow-capped mountains.



This formation of gas occurs through the process of

- A. diffusion.
- B. evaporation.
- C. sublimation.
- D. condensation.

16. A scientist prepared sugar solution in a sequence as shown below. He started dissolving sugar at room temperature and then raised the temperature to dissolve an excess amount. The solution was then cooled to a temperature where the scientist observed crystal formation.

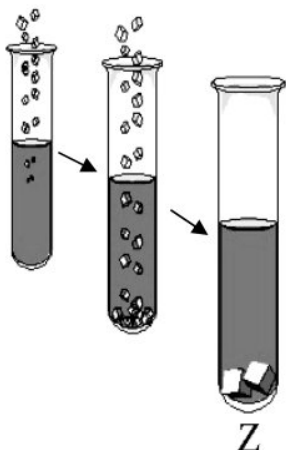

The solution **Z** which favoured the formation of crystals is said to be a/ an

- A. colloidal solution.
 B. saturated solution.
 C. unsaturated solution.
 D. supersaturated solution.
17. A concentrated solution is the one which is made up of
- A. more solute than solvent.
 B. more solvent than solute.
 C. known amount of solute and solvent.
 D. fixed amount of solute and solvent at 25°C.
18. Which of the following predictions is **WRONG** about the solubility of substance **X** in substance **Y**?

	Substance X	Substance Y	Solubility
A	Toluene	Benzene	Soluble
B	Sodium chloride	Water	Soluble
C	Grease	Water	Insoluble
D	Paint	Kerosene oil	Insoluble

19. $\text{H}_2\text{S}_{(g)} + \text{Cl}_{2(g)} \rightarrow \text{S}_{(s)} + 2\text{HCl}_{(g)}$

The oxidation state of chlorine gas in the given equation changes from

- A. 0 to +1
 B. 0 to -1
 C. -2 to 0
 D. -2 to -1

PLEASE TURN OVER THE PAGE

20. Which of the following CORRECTLY matches the redox reaction with its observation?

	Redox Reaction	Observation
A	$2\text{HI}_{(g)} + \text{Cl}_{2(g)} \rightarrow \text{I}_{2(g)} + 2\text{HCl}_{(g)}$	Hydrogen iodide is reduced into iodine.
B	$\text{Mg}_{(s)} + 2\text{HCl}_{(aq)} \rightarrow \text{MgCl}_{2(aq)} + \text{H}_{2(g)}$	Magnesium is reduced into magnesium chloride.
C	$\text{CuSO}_{4(aq)} + \text{Mg}_{(s)} \rightarrow \text{MgSO}_{4(aq)} + \text{Cu}_{(s)}$	Copper sulphate is reduced into copper.
D	$\text{H}_2\text{S}_{(g)} + \text{Cl}_{2(g)} \rightarrow \text{S}_{(s)} + 2\text{HCl}_{(g)}$	Hydrogen sulphide is reduced into sulphur.

21. Following diagrams show electrolytic cells with different chemical substances. In which of the electrolytic cells will the bulb NOT glow?

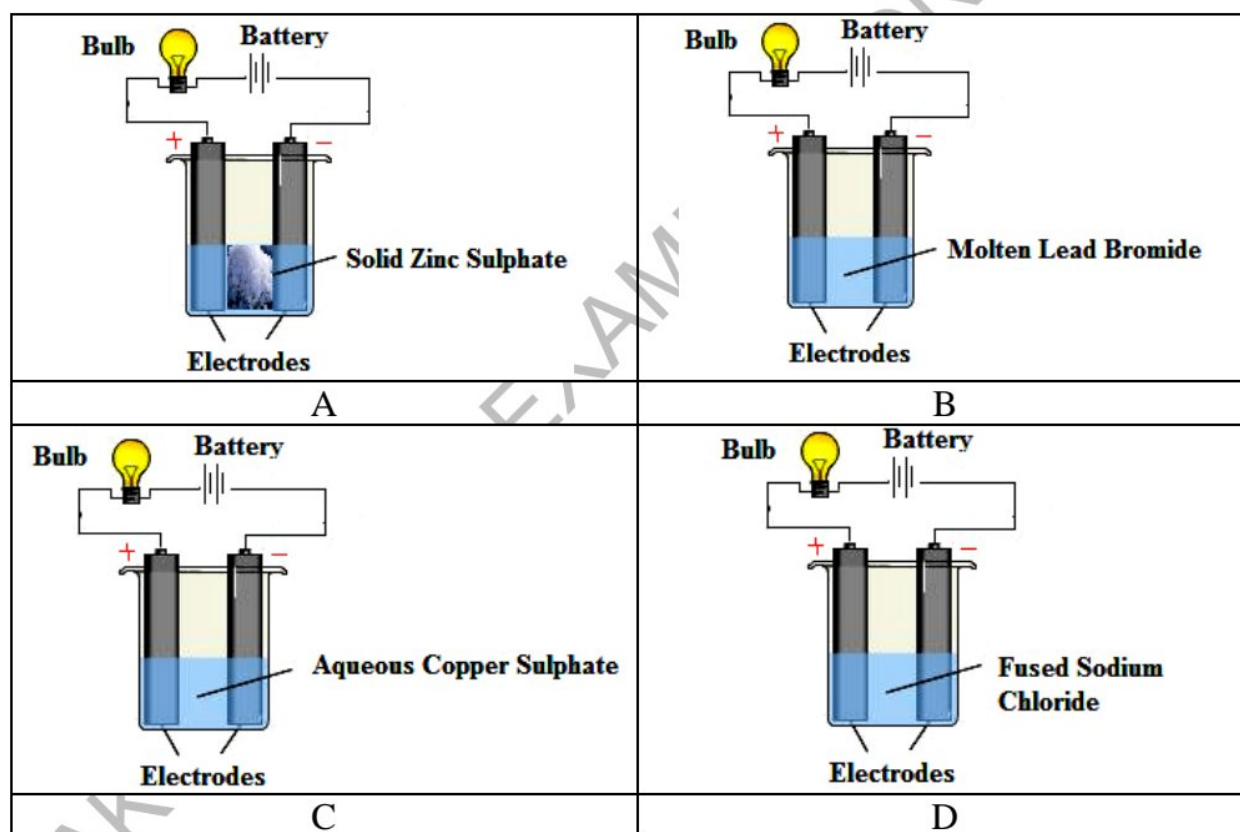

22. A metallic anchor is used to prevent ships from drifting due to wind or ocean current.

Anchors are often made up of iron because it

- A. is sonorous.
- B. is unreactive.
- C. has high density.
- D. has low melting point.

23. What will happen when a small piece of burning sodium metal on a combustion spoon is introduced in a gas jar containing oxygen gas?
- A. It will not react with oxygen gas.
 - B. It will react violently to form oxide.
 - C. It will react slowly to form superoxide.
 - D. It will react violently to form hydroxide.
24. An element which forms a cation with +2 charge is a/ an
- A. halogen.
 - B. noble gas.
 - C. alkali metal.
 - D. alkaline earth metal.
25. Gold and silver are considered as noble metals because they
- A. are lustrous.
 - B. are highly ductile.
 - C. do not form alloys.
 - D. do not oxidize easily.

AKU-EB MAY EXAMINATIONS 2016

AGA KHAN UNIVERSITY EXAMINATION BOARD

SECONDARY SCHOOL CERTIFICATE

CLASS IX EXAMINATION

APRIL/ MAY 2017

Chemistry Paper I

Time: 35 minutes Marks: 25

INSTRUCTIONS

1. Read each question carefully.
2. Answer the questions on the separate answer sheet provided. DO NOT write your answers on the question paper.
3. There are 100 answer numbers on the answer sheet. Use answer numbers 1 to 25 only.
4. In each question there are four choices A, B, C, D. Choose ONE. On the answer grid black out the circle for your choice with a pencil as shown below.

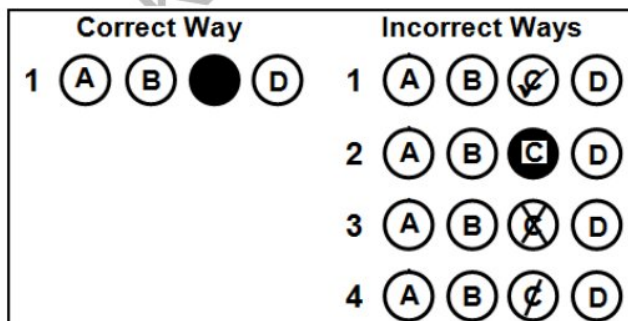

Candidate's Signature

5. If you want to change your answer, ERASE the first answer completely with a rubber, before blacking out a new circle.
6. DO NOT write anything in the answer grid. The computer only records what is in the circles.
7. You may use a simple calculator if you wish.

1. The branch of chemistry which deals with the study of chemical and biochemical phenomena occurring in nature is called
- nuclear chemistry.
 - physical chemistry.
 - analytical chemistry.
 - environmental chemistry.
2. A sample of hydrocarbon undergoes complete combustion to produce carbon dioxide (CO_2) and water (H_2O).

(Note: Atomic mass of C = 12 amu, O = 16 amu and H = 1 amu)

If 8.80 g of carbon dioxide is obtained, then what will be the mass of carbon present in it?

- 2.4 g
 - 3.8 g
 - 12.0 g
 - 32.3 g
3. A student has to identify the element, mixture and compound in the given substances.

i. Mercury	ii. Glucose	iii. Ammonia	iv. Brass
------------	-------------	--------------	-----------

Which of the following arrangements is CORRECT for the given substances?

	i	ii	iii	iv
A	Element	Compound	Mixture	Element
B	Element	Compound	Compound	Mixture
C	Compound	Element	Mixture	Compound
D	Compound	Mixture	Mixture	Element

4. Tritium is an isotope of hydrogen.

Which figure shows the atomic structure of tritium?

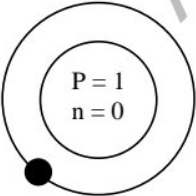
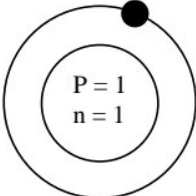
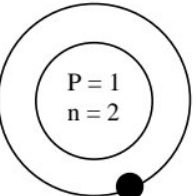
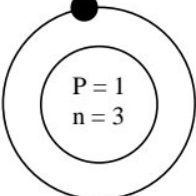
			
A	B	C	D

5. How many neutrons are present in an atom with atomic number 9 and mass number 19?
- 9
 - 10
 - 19
 - 28
6. Which of the following represents the electronic configuration of potassium (${}_{19}^{39}\text{K}$)?
- $1s^2, 2s^2, 2p^6, 3s^2, 3p^5$
 - $1s^2, 2s^2, 2p^6, 3s^2, 3p^6$
 - $1s^2, 2s^2, 2p^6, 3s^2, 3p^6, 4s^1$
 - $1s^2, 2s^2, 2p^6, 3s^2, 3p^6, 4s^2$
7. The tendency of an atom to have eight electrons in its valence shell, either by gaining, losing or sharing electrons to attain an electronic configuration of the nearest noble gas, is called
- octet rule.
 - duplet rule.
 - periodic law.
 - aufbau principle.
8. Which of the following statements is FALSE about polar covalent compounds?
- They dissolve completely in water.
 - They show electronegativity difference as zero.
 - They carry partial positive and negative charges.
 - They have unequal sharing of electrons between bonded atoms.
9. Which of the following bonds is present between copper atoms that allows copper to conduct electricity?
- Ionic bond
 - Metallic bond
 - Covalent bond
 - Co-ordinate covalent bond
10. Neon and argon are classified as noble gases because they have
- coloured vapours.
 - same atomic number.
 - non-metallic character.
 - full outer electron shell.
11. Which periodic trend is observed in moving down group VIIA of the periodic table?
- Decreasing reactivity
 - Decreasing boiling point
 - Increasing electronegativity
 - Increasing ionisation energy

PLEASE TURN OVER THE PAGE

12. In the periodic table, the group number of an element shows its
- A. valency.
 - B. atomic number.
 - C. number of shells.
 - D. number of valence electrons.
13. When few drops of ink are added in water, they slowly start to disperse. This spreading of molecules can be enhanced by increasing temperature.

What will be the impact on the molecules when the temperature is increased?

- A. Velocity of the molecules will increase.
 - B. Pressure on the molecules will decrease.
 - C. Intermolecular forces of attraction will increase.
 - D. Volume occupied by the molecules will decrease.
14. Plastics are amorphous solids because they
- A. have a sharp melting point.
 - B. can be broken along definite planes.
 - C. maintain a 3-dimensional geometrical shape.
 - D. possess an irregular arrangement of particles.
15. The gas law which shows the relationship between volume and pressure at constant temperature was presented by
- A. Robert Boyle.
 - B. Henry Moseley.
 - C. Jacques Charles.
 - D. Thomas Graham.
16. Which of the following is NOT an example of aqueous solution?
- A. Black tea
 - B. Sea water
 - C. Orange juice
 - D. Whipped cream
17. If 16 cm^3 of acetone is dissolved in water to prepare 200 cm^3 of aqueous solution, the volume/volume (v/v) percentage of this solution will be
- A. 0.07%
 - B. 0.08%
 - C. 7.41%
 - D. 8.00%

18. The molarity of the given sodium hydroxide solution will be
(Note: Atomic mass of Na = 23 amu, O = 16 amu, H = 1 amu)

A. 0.03 M
B. 0.19 M
C. 0.79 M
D. 1.26 M

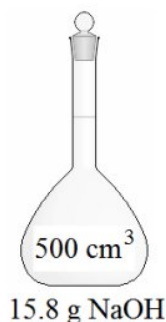

19. Glucose is a non-electrolyte because it
- A. is a polar molecule.
B. is a covalent compound.
C. breaks up into ions in water.
D. dissolves completely in water.
20. All of the following can prevent corrosion of metals EXCEPT
- A. applying lubricants on the metals.
B. alloying the metals with other metals.
C. dipping the metals in aqueous salt solution.
D. covering the metals with more reactive metals.
21. A voltaic (galvanic) cell is an electrochemical cell which
- A. converts electrical energy into chemical energy.
B. generates electricity through spontaneous redox reaction.
C. comprises of two electrodes made up of the same inert metal.
D. consists of a positively charged anode and a negatively charged cathode.
22. The shape of non-metals cannot be changed by hammering because they are
- A. brittle.
B. ductile.
C. malleable.
D. electronegative.
23. Alkali metals are highly reactive because they have
- A. high ionisation energy values.
B. low melting and boiling points.
C. one electron in their valence shell.
D. two electrons in their valence shell.
24. Which statement is FALSE about sodium metal?
- A. It is silvery white and soft in appearance.
B. It reacts with oxygen to form an acidic oxide.
C. It forms salt with halogen having NaX formula.
D. It liberates hydrogen gas on reaction with water.

PLEASE TURN OVER THE PAGE

25. Which of the following is TRUE when ionisation energies of sodium (Na) metal are compared with magnesium (Mg) metal?

	1st Ionisation Energy	2nd Ionisation Energy
A	Na < Mg	Na > Mg
B	Na > Mg	Na = Mg
C	Na = Mg	Na > Mg
D	Na > Mg	Na < Mg

AKU-EB May Examination 2017

AGA KHAN UNIVERSITY EXAMINATION BOARD

SECONDARY SCHOOL CERTIFICATE

CLASS IX EXAMINATION

APRIL/ MAY 2018

Chemistry Paper I

Time: 35 minutes Marks: 25

INSTRUCTIONS

1. Read each question carefully.
2. Answer the questions on the separate answer sheet provided. DO NOT write your answers on the question paper.
3. There are 100 answer numbers on the answer sheet. Use answer numbers 1 to 25 only.
4. In each question there are four choices A, B, C, D. Choose ONE. On the answer grid black out the circle for your choice with a pencil as shown below.

Correct Way	Incorrect Ways
1 (A) (B) ● (D)	1 (A) (B) (C) (D)
	2 (A) (B) (C) (D)
	3 (A) (B) (C) (D)
	4 (A) (B) (C) (D)

Candidate's Signature

5. If you want to change your answer, ERASE the first answer completely with a rubber, before blacking out a new circle.
6. DO NOT write anything in the answer grid. The computer only records what is in the circles.
7. You may use a simple calculator if you wish.

1. What is the valency of iron (Fe) in $\text{Fe}(\text{NO}_3)_3$?

- A. 0
- B. 1
- C. 2
- D. 3

2. $\underline{w}\text{NH}_{3(g)} + \underline{x}\text{O}_{2(g)} \rightarrow \underline{y}\text{NO}_{(g)} + 6\text{H}_2\text{O}_{(g)}$

The values of **w**, **x** and **y** in the given chemical equation are

	w	x	y
A	2	5	2
B	2	3	2
C	4	5	4
D	4	3	4

3. A compound **X** has an empirical formula C_4H_9 and its molecular mass is 114 g/mol.

Which of the following represents the molecular formula of compound **X**?

(Note: $^{12}_6\text{C}$ and ^1_1H)

- A. C_6H_{11}
- B. C_7H_{12}
- C. C_8H_{18}
- D. $\text{C}_{12}\text{H}_{27}$

4. Which of the following options shows the sub-atomic particles of a species having a +1 charge on it?

	Number of Electrons	Number of Protons	Number of Neutrons
A	18	20	20
B	18	19	20
C	10	9	10
D	10	8	8

5. Rutherford's atomic model explains all of the following statements EXCEPT that the

- A. volume occupied by the nucleus is very small.
- B. positively charged particles exist inside the nucleus.
- C. entire mass of the atom is concentrated in the nucleus.
- D. energy emitted by the electrons forms a line spectrum.

6. Goiter, a disease affecting thyroid glands, can be diagnosed by the use of
- cobalt-60.
 - iodine-131.
 - strontium-90.
 - uranium-235.
7. In a molecule of ethyne (C_2H_2), how many electron pairs are involved in the bonding between carbon-carbon atoms?
- 2
 - 3
 - 4
 - 5

8. Read the given characteristics.

- Usually dissolve in water
- Carry partial charges on atoms
- Uneven distribution of electrons

Based on the given characteristics, an example of polar covalent molecule is

- O_2
 - Cl_2
 - H_2S
 - $NaCl$
9. $\left[\begin{array}{c} \bullet\bullet \\ \bullet Cl \times \\ \bullet\bullet \end{array} \right]^{-} \left[Mg \right]^{2+} \left[\begin{array}{c} \bullet\bullet \\ \times Cl \\ \bullet\bullet \end{array} \right]^{-}$
 (2,8,8) (2,8) (2,8,8)

In the given dot and cross structure of magnesium chloride, magnesium ion is bonded to two chloride ions by

- ionic bonds.
 - metallic bonds.
 - covalent bonds.
 - coordinate covalent bonds.
10. Which of the following statements is FALSE regarding ionisation energy of elements?
- The first ionisation energy of lithium is less than that of beryllium.
 - The second ionisation energy of magnesium is less than that of sodium.
 - It is the amount of energy required to remove an electron from a gaseous atom or ion.
 - It is the tendency of an atom or molecule to attract electrons of other atom or molecule to itself.

11. Which of the following statements is CORRECT about groups in the periodic table?
- A. Both metals and non-metals are present in all groups.
 - B. Reactivity in non-metals increases when moving up a group.
 - C. Ionisation energy of elements increases when moving down a group.
 - D. The total number of electrons for each element in a group is the same.
12. In which period of the periodic table, an element with atomic number 14 is placed?
- A. 1
 - B. 2
 - C. 3
 - D. 4
13. At constant temperature and pressure, which of the following gas molecules will diffuse the fastest through air?
- (Note: Atomic mass of O = 16 amu, Cl = 35.5 amu, N = 14 amu, C = 12 amu and H = 1 amu)
- A. $\text{O}_{2(g)}$
 - B. $\text{Cl}_{2(g)}$
 - C. $\text{NO}_{2(g)}$
 - D. $\text{CH}_{4(g)}$
14. At constant temperature, if the volume of a gas in a container is reduced to half, then the pressure on the gas will
- A. be doubled.
 - B. reduce to half.
 - C. remain the same.
 - D. reduce to a quarter.
15. Which of the following substances does NOT have a fixed volume and can be compressed?
- A. Sugar
 - B. Honey
 - C. Kerosene oil
 - D. Water vapour
16. What is the molarity of a solution containing 32 g of potassium sulphate (K_2SO_4) in 350 cm^3 of solution?
- (Note: Molar mass of $\text{K}_2\text{SO}_4 = 174 \text{ g mol}^{-1}$)
- A. 0.06 M
 - B. 0.09 M
 - C. 0.52 M
 - D. 64.37 M

17. The given diagram shows an area covered in fog.



Fog is a solution of

- A. gas in liquid.
 B. liquid in gas.
 C. solid in liquid.
 D. liquid in liquid.
18. Which of the following differences between solution and suspension is INCORRECT?

	Solution	Suspension
A	It passes through the filter paper.	It leaves residue on filtration.
B	It forms homogeneous mixture.	It forms heterogeneous mixture.
C	It does not show Tyndall effect.	It may show Tyndall effect.
D	It appears translucent.	It appears transparent.

19. Which of the following CORRECTLY matches the redox reaction with its observation?

	Redox Reaction	Observation
A	$2\text{HI}_{(g)} + \text{Cl}_{2(g)} \rightarrow \text{I}_{2(g)} + 2\text{HCl}_{(g)}$	Hydrogen iodide is reduced to iodine.
B	$\text{Mg}_{(s)} + 2\text{HCl}_{(aq)} \rightarrow \text{MgCl}_{2(aq)} + \text{H}_{2(g)}$	Magnesium is reduced to magnesium chloride.
C	$\text{CuSO}_{4(aq)} + \text{Mg}_{(s)} \rightarrow \text{MgSO}_{4(aq)} + \text{Cu}_{(s)}$	Copper sulphate is reduced to copper.
D	$\text{H}_2\text{S}_{(g)} + \text{Cl}_{2(g)} \rightarrow \text{S}_{(s)} + 2\text{HCl}_{(g)}$	Hydrogen sulphide is reduced to sulphur.

20. The gas(es) produced during the electrolysis of fused sodium chloride in Down's cell is/ are

- I. $\text{Cl}_{2(g)}$
 II. $\text{O}_{2(g)}$
 III. $\text{H}_{2(g)}$
- A. I only
 B. III only
 C. I and II
 D. I and III

PLEASE TURN OVER THE PAGE

21. Which of the following is an example of electrolyte?
- A. Benzene
 - B. Sulphuric acid
 - C. Distilled water
 - D. Carbon tetrachloride
22. Metals are good conductors of electricity due to the presence of
- A. freely moving electrons.
 - B. number of positive charges on the ions.
 - C. atoms in the form of rows one above the other.
 - D. electrostatic forces of attraction between oppositely charged ions.
23. Barium belongs to group IIA while chlorine belongs to group VIIA of the modern periodic table.
- If barium reacts with chlorine, then their product is
- A. BaCl
 - B. BaCl₂
 - C. Ba₂Cl
 - D. Ba₂Cl₂
24. Compared to a sodium metal, an iron metal
- A. is soft in appearance.
 - B. has low melting point.
 - C. is an alkaline earth metal.
 - D. has stronger metallic bond.
25. Sodium metal is always found in nature in the form of oxides or halides because sodium
- A. is highly electropositive.
 - B. is highly electronegative.
 - C. has high electron affinity.
 - D. has high ionisation energy.

1. A heterogeneous mixture is formed when water is added to
 - A. butter.
 - B. honey.
 - C. glucose.
 - D. alcohol.
2. Which of the following diagrams represents a pure compound?

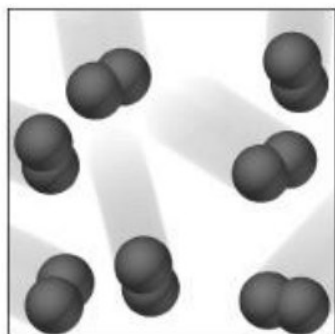

A

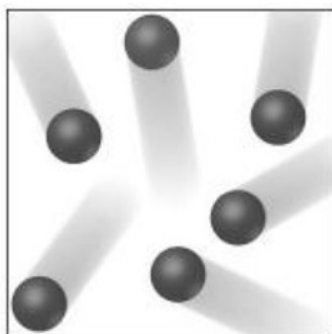

B

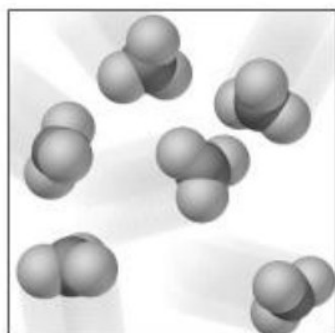

C

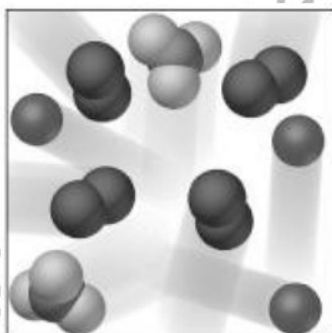

D

3. The branch of chemistry that emphasises on plantation to overcome greenhouse effect is
 - A. biochemistry.
 - B. organic chemistry.
 - C. physical chemistry.
 - D. environmental chemistry.
4. Ozone (O_3) is a highly reactive gas which is formed in the stratosphere with the help of ultraviolet radiations.

If 10.5 moles of ozone gas is formed in the stratosphere, then its mass in grams will be

(Note: $^{16}_8O$)

- A. 84
- B. 168
- C. 252
- D. 504

5. Which of the following bond(s) is/ are present in NH_4^+ ?

- I. Coordinate covalent
 - II. Covalent
 - III. Ionic
- A. I only
 - B. III only
 - C. I and II
 - D. II and III

6. Which of the following properties is TRUE for ionic compounds?

- A. They are malleable and ductile.
- B. They have low melting and boiling points.
- C. They are brittle and dissolve easily in non-polar solvents.
- D. They dissolve in polar solvents and conduct electricity in molten form.

7. The dot and cross structure for the molecule of hydrogen sulphide is

(Note: ${}^1_1\text{H}$ and ${}^{32}_{16}\text{S}$)

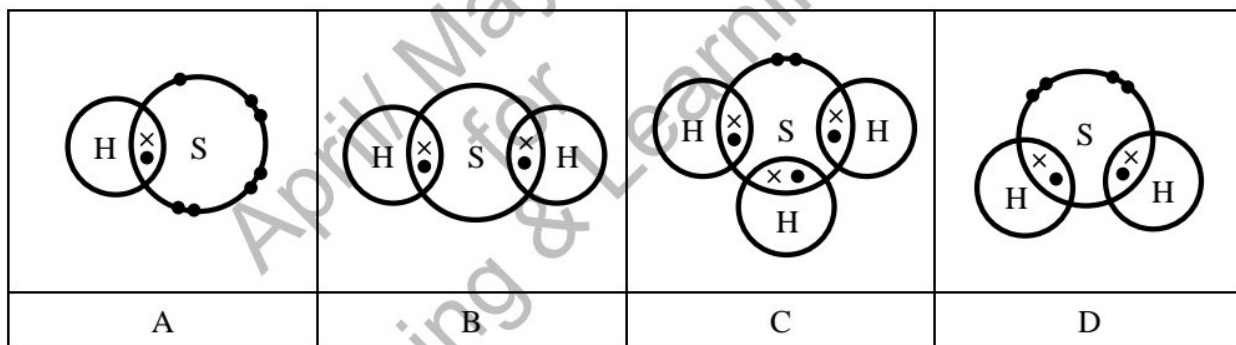

8. An element X belongs to group 15 and period 3 of the modern periodic table.

The number of electrons that would be present in the valence shell of the given element is

- A. 3
- B. 5
- C. 15
- D. 18

9. Among the given solutions of potassium permanganate (KMnO_4), which one has the highest concentration of water in it?

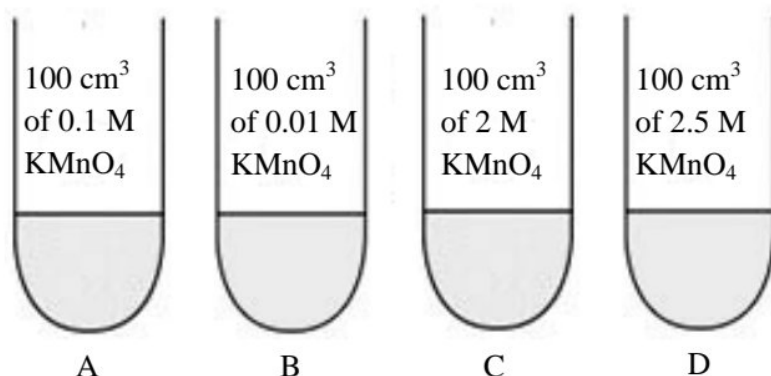

10. A student, for his research, prepared 1.25 M potassium chloride stock solution. What volume of the stock solution will he use to further prepare a 250 mL dilute solution of 0.2 M ?
- A. 40 mL
 - B. 50 mL
 - C. 62.5 mL
 - D. 250 mL
11. Which of the following is NOT a solution?
- A. Fog
 - B. Butter
 - C. Bronze
 - D. Ammonia
12. Which of the following statements defines a solution?
- A. A pure compound having one or more solutes dissolved in a solvent
 - B. A homogeneous mixture having one or more solutes dissolved in a solvent
 - C. A heterogeneous mixture having one or more solutes dissolved in a solvent
 - D. A pure compound having a solute and a solvent mixed in a fixed ratio by mass
13. In the periodic table, the group which consists of purely metals is
- A. IIA
 - B. IIIA
 - C. VA
 - D. VIIIA
14. The valence shell electronic configuration of the most electronegative element of the periodic table is
- A. ns^2np^3
 - B. ns^2np^4
 - C. ns^2np^5
 - D. ns^2np^6

15. An oxygen atom is similar to an atom of sulphur because they both
- A. form diatomic molecules.
 - B. have the same number of protons.
 - C. form cations with a double negative charge.
 - D. have the same number of valence electrons.
16. Which periodic trend is observed in moving down group 17 of the modern periodic table?
- A. Decreasing reactivity
 - B. Decreasing boiling point
 - C. Increasing electronegativity
 - D. Increasing ionisation energy
17. The given table shows four different atoms, P, Q, R and S.

Atom	Number of Protons	Number of Neutrons	Number of Electrons
P	17	18	17
Q	18	22	18
R	19	20	19
S	17	20	17

Which two atoms in the given table are isotopes of each other?

- A. P and Q
 - B. Q and R
 - C. R and S
 - D. P and S
18. If an element X has atomic number 15, then its valence shell electronic configuration will be
- A. $2s^1, 2p^4$
 - B. $2s^2, 2p^3$
 - C. $3s^1, 3p^4$
 - D. $3s^2, 3p^3$

19. The atomic structure of boron (${}^1_5\text{B}$) is represented by

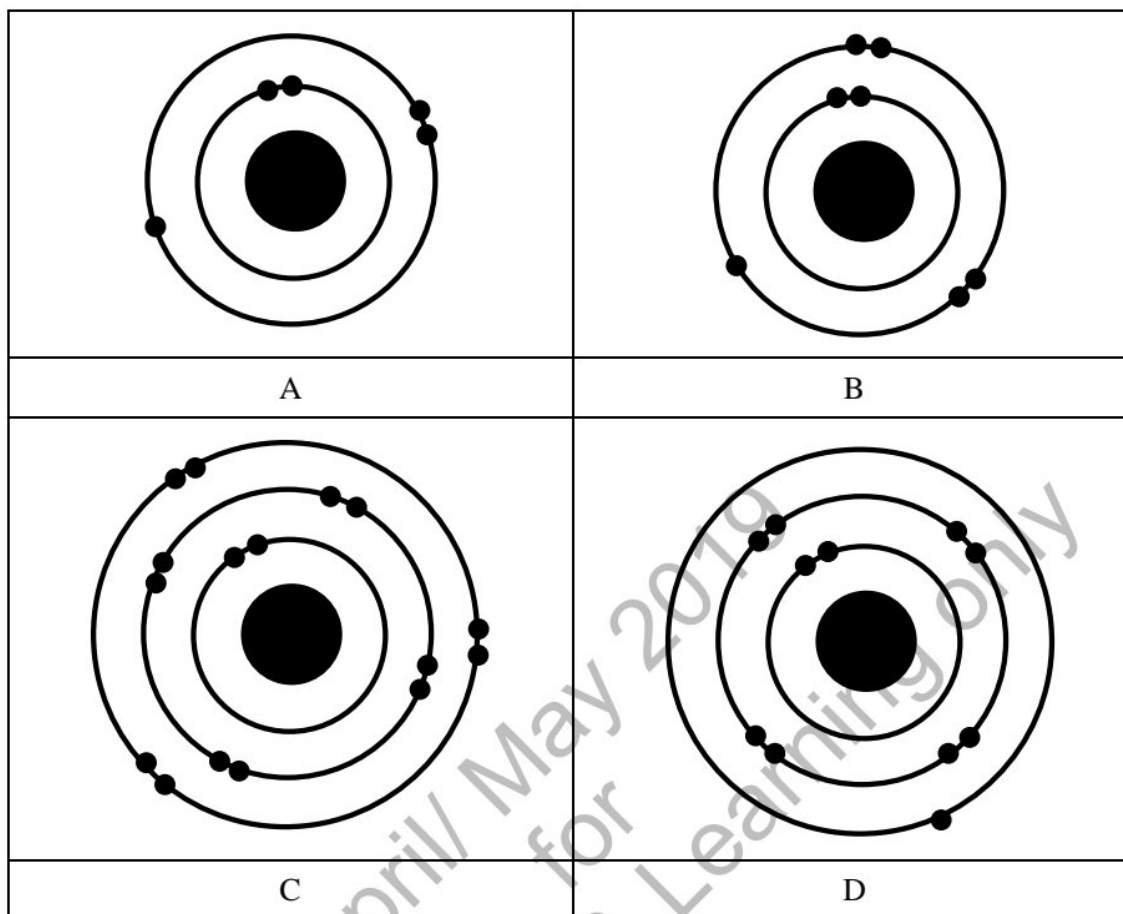

20. Which of the following statements is TRUE about Bohr's atomic model?

- A. It shows that an atom produces continuous spectrum.
- B. It proves that the plum-pudding model of an atom was correct.
- C. It proves that the size and energy of each orbit in an atom is quantised.
- D. It shows that electrons emit radiation when revolving around the nucleus.

21. Solids, liquids and gases differ from each other on the basis of all of the following EXCEPT

- A. size of particles.
- B. velocity of particles.
- C. space among particles.
- D. arrangement of particles.

22. Sulphur dioxide and methane gas have different rates of diffusion at a fixed temperature because they both have different

- A. chemical bonding.
- B. molecular masses.
- C. molecular formula.
- D. intermolecular forces.

23. The given diagram shows the process of

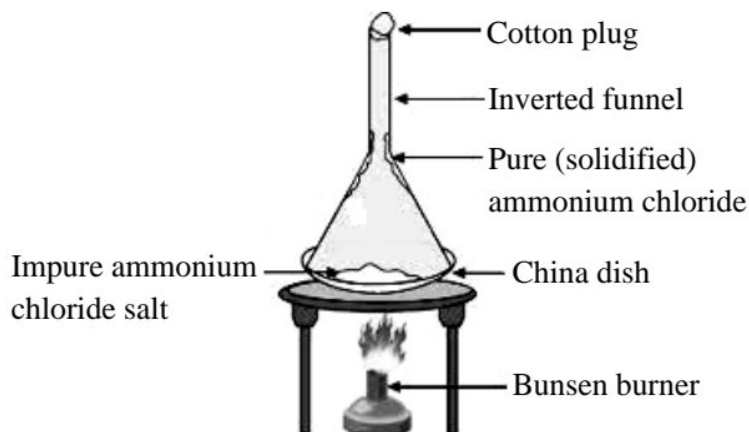

- A. boiling.
 B. melting.
 C. sublimation.
 D. condensation.
24. Liquids can be converted into solids by
- A. increasing collision among the molecules.
 B. decreasing kinetic energy of the molecules.
 C. increasing volume occupied by the molecules.
 D. decreasing force of attraction among the molecules.
25. The following diagram shows an electrolytic cell used for electroplating iron with chromium.

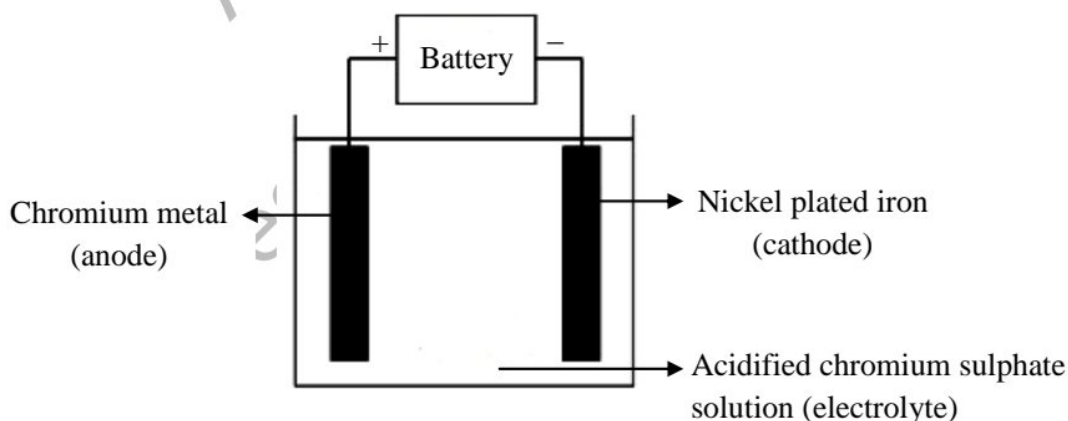

The chemical reaction that takes place at cathode is

- A. $\text{Cr}_{(s)} \rightarrow \text{Cr}_{(aq)}^{2+} + 2e^{-}$
 B. $\text{Cr}_{(aq)}^{2+} + 2e^{-} \rightarrow \text{Cr}_{(s)}$
 C. $\text{Cr}_{(s)} \rightarrow \text{Cr}_{(aq)}^{3+} + 3e^{-}$
 D. $\text{Cr}_{(aq)}^{3+} + 3e^{-} \rightarrow \text{Cr}_{(s)}$

PLEASE TURN OVER THE PAGE

26. The oxidation state of chlorine in ClO_3^- is
- +1
 - +3
 - +5
 - +7
27. A voltaic (galvanic) cell is an electrochemical cell which
- converts electrical energy into chemical energy.
 - generates electricity through spontaneous redox reaction.
 - comprises of two electrodes made up of the same inert metal.
 - consists of a positively charged anode and a negatively charged cathode.
28. Like metals, most of the non-metals react with oxygen to form oxides. The nature of the oxides of non-metals, with a few exceptions, is
- basic.
 - acidic.
 - neutral.
 - amphoteric.
29. Silver is a noble metal because it is
- highly ductile and malleable.
 - white lustrous in appearance.
 - resistant to oxidation in moist air.
 - poor conductor of heat and electricity.
30. Which of the following classification of metals is CORRECT?

	Alkali Metal	Alkaline Earth Metal
A	Sodium	Cesium
B	Beryllium	Lithium
C	Rubidium	Strontium
D	Barium	Calcium

AGA KHAN UNIVERSITY EXAMINATION BOARD
SECONDARY SCHOOL CERTIFICATE
CLASS IX
ANNUAL EXAMINATIONS 2021
Chemistry
Total Time: 1 hour 40 minutes
Total Marks: 50 (40-Theory & 10-Alternate to Practical)

INSTRUCTIONS

1. Read each question carefully.
2. Answer the questions on the separate answer sheet provided. DO NOT write your answers on the question paper.
3. There are 100 answer numbers on the answer sheet. Use answer numbers 1 to 50 only.
4. Question Distribution:

Theory	Alternate to Practical (ATP)
40 MCQs	10 MCQs

5. In each question, there are four choices A, B, C, D. Choose ONE. On the answer grid, black out the circle for your choice with a pencil as shown below.

Correct Way	Incorrect Ways
1 (A) (B) (●) (D)	1 (A) (B) (C) (D)
	2 (A) (B) (C) (D)
	3 (A) (B) (C) (D)
	4 (A) (B) (C) (D)

Candidate's Signature

6. If you want to change your answer, ERASE the first answer completely with a rubber, before blacking out a new circle.
7. DO NOT write anything in the answer grid. The computer only records what is in the circles.
8. The marks obtained on the 40 MCQs will be equated to the total marks of 65 for the theory examination results.
9. You may use a simple calculator if you wish.

THEORY (Questions 1-40)

1. If hydrogen is replaced with deuterium in each of the given compounds, then the formula of which of these is written INCORRECTLY?

- A. DF
- B. ND₃
- C. MgOD
- D. C₂D₅OD

2. How many atoms of chlorine are there in 250 g of chlorine gas?

(Note: $^{35.5}_{17}\text{Cl}$)

- A. 2.12×10^{24}
- B. 4.24×10^{24}
- C. 4.43×10^{24}
- D. 8.85×10^{24}

3. Which of the following chemical equations is balanced?

- A. $\text{CH}_4(\text{g}) + \text{O}_2(\text{g}) \rightarrow \text{CO}_2(\text{g}) + \text{H}_2\text{O}(\text{g})$
- B. $\text{NaCl}(\text{aq}) + \text{BeF}_2(\text{aq}) \rightarrow \text{NaF}(\text{aq}) + \text{BeCl}_2(\text{s})$
- C. $\text{AgNO}_3(\text{aq}) + \text{LiOH}(\text{aq}) \rightarrow \text{AgOH}(\text{s}) + \text{LiNO}_3(\text{aq})$
- D. $\text{Al}_2(\text{SO}_4)_3(\text{aq}) + \text{CaCl}_2(\text{aq}) \rightarrow \text{AlCl}_3(\text{aq}) + \text{CaSO}_4(\text{s})$

4. Which of the following diagrams represents a pure compound?

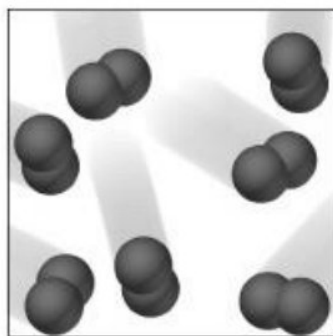

A

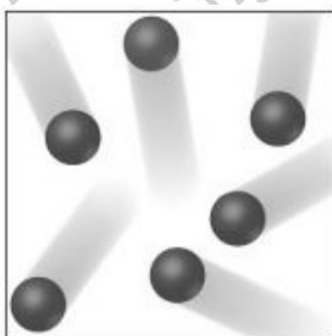

B

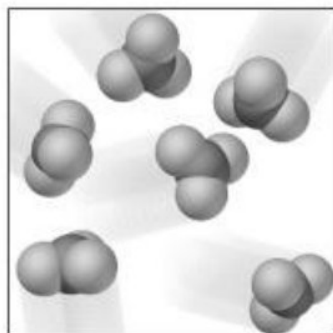

C

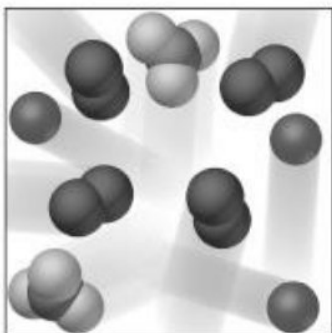

D

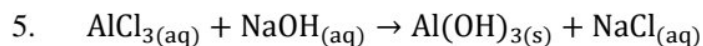

To balance the given equation, the coefficient '3' should be placed before

- A. $\text{AlCl}_{3(\text{aq})}$ and $\text{NaCl}_{(\text{aq})}$
- B. $\text{NaOH}_{(\text{aq})}$ and $\text{NaCl}_{(\text{aq})}$
- C. $\text{AlCl}_{3(\text{aq})}$ and $\text{Al}(\text{OH})_{3(\text{s})}$
- D. $\text{NaOH}_{(\text{aq})}$ and $\text{Al}(\text{OH})_{3(\text{s})}$

6. A compound **X** has an empirical formula C_4H_9 and its molecular mass is 114 g/mol.

Which of the following represents the molecular formula of compound **X**?

(Note: $^{12}_6\text{C}$ and ^1_1H)

- A. C_6H_{11}
- B. C_7H_{12}
- C. C_8H_{18}
- D. $\text{C}_{12}\text{H}_{27}$

7. Molecular formula of hexane is C_7H_{16} and that of calcium carbonate is CaCO_3 .

One mole of these substances contains the same

(Note: $^{12}_6\text{C}$, ^1_1H , $^{40}_{20}\text{Ca}$ and $^{16}_8\text{O}$)

- A. type of atoms.
- B. type of bonding.
- C. number of atoms.
- D. number of grams.

8. The species that does NOT carry an electrical charge is a/ an

- A. anion.
- B. cation.
- C. proton.
- D. neutron.

9. Which of the following statements is TRUE for $^{40}_{18}\text{Ar}$?

- A. It contains an equal number of protons and neutrons.
- B. It contains more number of neutrons than electrons.
- C. It contains more number of electrons than protons.
- D. It contains more number of protons than neutrons.

10. In Rutherford's experiment which led to the discovery of atomic nucleus, the alpha particles were bombarded on a very thin sheet of gold foil.

These alpha particles are positively charged and each particle consists of

- A. one proton and one neutron.
 - B. one proton and two neutrons.
 - C. two protons and one neutron.
 - D. two protons and two neutrons.
11. A metal compound has the formula XCl_2 and a relative formula mass of 95.211.
- The relative atomic mass of X is
- (Note: $^{35.5}_{17}Cl$)
- A. 24.211
 - B. 59.711
 - C. 61.211
 - D. 78.211
12. Which of the following statements is TRUE about Bohr's atomic model?
- A. It shows that an atom produces continuous spectrum.
 - B. It proves that the energy of each orbit in an atom is quantised.
 - C. It proves that the plum-pudding model of an atom was correct.
 - D. It shows that electrons emit radiations when revolving around the nucleus.
13. An atom of hydrogen contains one proton and zero neutrons. Suppose a neutron is added to the nucleus of hydrogen atom.
- This addition of one neutron will cause
- A. an increase in the positive charge on the nucleus.
 - B. the hydrogen atom to convert into one of its isotopes.
 - C. an increase in the atomic number of the hydrogen atom.
 - D. the hydrogen atom to convert into a new atom of a different element.
14. In contrast to group II elements, group I elements are less
- A. hard.
 - B. reactive.
 - C. electropositive.
 - D. metallic in character.
15. Which periodic trend is observed in moving down group 17 of the modern periodic table?
- A. Decreasing reactivity
 - B. Decreasing boiling point
 - C. Increasing electronegativity
 - D. Increasing ionisation energy

16. An element has atomic number 14.

In which period of the periodic table will it be placed?

- A. 1
B. 2
C. 3
D. 4
17. The horizontal rows in the modern periodic table are known as
- A. shells.
B. blocks.
C. groups.
D. periods.
18. According to the modern periodic law, the elements in the periodic table are arranged as per their
- A. proton number.
B. neutron number.
C. nucleon number.
D. valence shell electrons.
19. The following table shows the difference between all the elements of **X** and **Y** families.

Property	X	Y
Reactivity	Unreactive	Reactive
Occurrence	Monoatomic	Diatomic

With reference to the given table, **X** and **Y** families can be identified as

	X	Y
A	noble gases	oxygen group
B	alkali metals	halogens
C	noble gases	halogens
D	alkali metals	oxygen group

20. The ion of an element, Z^{-3} has atomic mass 31 and atomic number 15.

How many valence electrons are present in element **Z**?

- A. 5
B. 8
C. 12
D. 15

PLEASE TURN OVER THE PAGE

21. The dot and cross structure for the molecule of hydrogen sulphide is

(Note: ${}^1_1\text{H}$ and ${}^{32}_{16}\text{S}$)

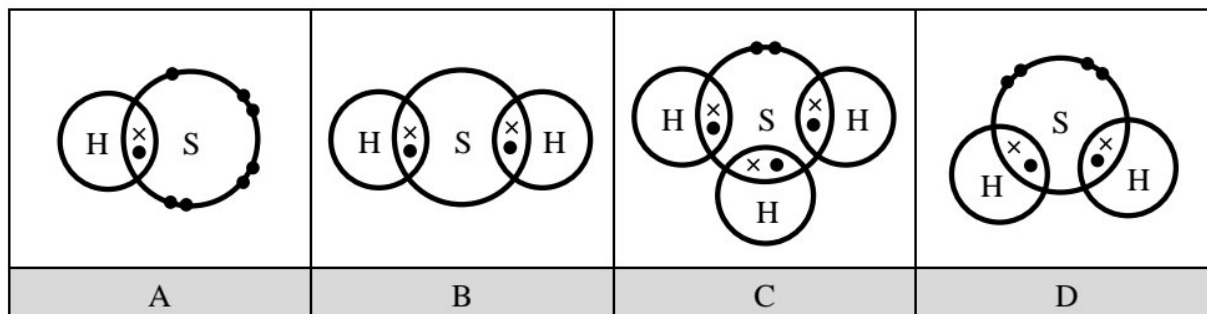

22. Which of the following properties is TRUE for ionic compounds?

- A. They are malleable and ductile.
- B. They have low melting and boiling points.
- C. They are brittle and dissolve easily in non-polar solvents.
- D. They dissolve in polar solvents and conduct electricity in molten form.

23. Compared to ionic and covalent bonds, intermolecular forces of attractions are

- A. weaker than both types of bonding.
- B. stronger than both types of bonding.
- C. stronger than ionic bonds but weaker than covalent bonds.
- D. stronger than covalent bonds but weaker than ionic bonds.

24. Atoms **P** and **Q**, belonging to the 2nd period of the modern periodic table, have 1 and 6 electrons in their valence shells respectively.

The compound which **P** and **Q** are likely to form is

- A. PQ
- B. PQ₂
- C. P₂Q
- D. P₃Q

25. ${}^{11}_5\text{B}$ and ${}^{27}_{13}\text{Al}$ are in the same group of the modern periodic table. Hence, they both have the same number of

- A. protons.
- B. neutrons.
- C. inner electrons.
- D. valence electrons.

26. On chemical combination, which of these elements can form triple covalent bonds?

- A. Two atoms of oxygen
- B. Two atoms of nitrogen
- C. Two atoms of sulphur and one atom of carbon
- D. Two atoms of oxygen and one atom of carbon

27. The given diagram shows a chromatogram of several inks.

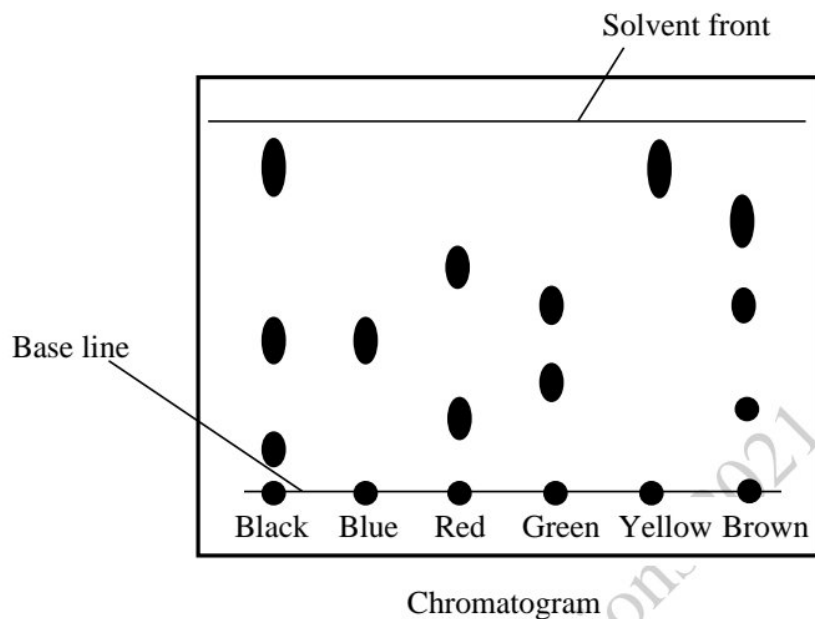

Based on the given chromatogram, it can be inferred that

- A. red and blue inks are present in brown ink.
 - B. yellow and blue inks are present in black ink.
 - C. black is a mixture of blue, red and green inks.
 - D. brown is a mixture of red, green and black inks.
28. Which of the following is NOT an example of aqueous solution?
- A. Black tea
 - B. Sea water
 - C. Orange juice
 - D. Whipped cream
29. What is the molarity of a solution containing 32 g of potassium sulphate (K_2SO_4) in 350 cm^3 of solution?
- (Note: Molar mass of $K_2SO_4 = 174\text{ g mol}^{-1}$)
- A. 0.06 M
 - B. 0.09 M
 - C. 0.52 M
 - D. 64.37 M

PLEASE TURN OVER THE PAGE

30. Sodium chloride crystals can be separated from sand using four different processes that are mentioned in the given table.

The option that shows the CORRECT order of these processes is

	First Process \longrightarrow			Last Process
A	filter	evaporate	dissolve	crystallise
B	dissolve	filter	evaporate	crystallise
C	dissolve	evaporate	crystallise	filter
D	filter	dissolve	crystallise	evaporate

31. If 16 g of sodium chloride is dissolved in water to prepare 200 cm³ of saline solution, the mass/volume (m/v) percentage of sodium chloride solution will be
- A. 0.07
B. 0.08
C. 7.41
D. 8.00
32. The given table shows the classification of substances based on their solubility in water.

	Soluble	Insoluble
I	Benzene	Magnesium hydroxide
II	Potassium sulphate	Magnesium hydroxide
III	Benzene	Carbon tetrachloride
IV	Potassium sulphate	Carbon tetrachloride

The option that shows the CORRECT classification of these substances is

- A. I and II.
B. I and III.
C. II and IV.
D. III and IV.
33. A fizzy (carbonated) drink is which type of solution?

	Solute	Solvent
A	Liquid	Liquid
B	Gas	Liquid
C	Gas	Gas
D	Liquid	Gas

34. Galvanising is one of the methods to prevent iron from rusting. This method involves coating of iron with a protective layer of
- A. tin.
 - B. zinc.
 - C. aluminium.
 - D. magnesium.
35. When molten sodium chloride is electrolysed, the chemical equation that shows the change taking place at the cathode is
- A. $\text{Na}_{(s)} - 2e^- \rightarrow \text{Na}_{(l)}^{2+}$
 - B. $\text{Na}_{(l)}^{2+} - 2e^- \rightarrow \text{Na}_{(s)}$
 - C. $\text{Na}_{(s)} + e^- \rightarrow \text{Na}_{(l)}^+$
 - D. $\text{Na}_{(l)}^+ + e^- \rightarrow \text{Na}_{(s)}$
36. An electrolytic cell does NOT show the use of
- A. inert metals as electrodes.
 - B. a battery to supply energy.
 - C. salt bridge to control the migration of ions.
 - D. single electrolyte for the conduction of ions.
37. When a piece of metal **M** is placed in an aqueous solution of metal **X** ions in a test tube, it is observed that the amount of solid metal (**M**) decreases while the solid metal (**X**) deposits at the bottom of the test tube over time.

The option that shows the CORRECT representation of metal **M** and **X** is

	M	X
A	iron	aluminium
B	iron	sodium
C	zinc	copper
D	zinc	magnesium

38. When an aqueous solution of sodium chloride is electrolysed, the substance that is produced at the cathode is
- A. oxygen gas.
 - B. chlorine gas.
 - C. hydrogen gas.
 - D. sodium metal.

PLEASE TURN OVER THE PAGE

39. To prevent underground iron pipes from rapid corrosion, blocks of metal **X** are buried close to the pipes and connected by wires. This is called sacrificial protection.

The metal **X** is

- A. tin.
 - B. lead.
 - C. copper.
 - D. magnesium.
40. Which of the following is an example of electrolyte?
- A. Benzene
 - B. Sulphuric acid
 - C. Distilled water
 - D. Carbon tetrachloride

ALTERNATE TO PRACTICAL (ATP: Questions 41-50)

41. A student separated a mixture of ammonium chloride and iron filings using a magnet. This is because iron is
- A. highly electronegative.
 - B. highly electropositive.
 - C. a metallic solid.
 - D. an ionic solid.
42. A suspension is filtered using the following setup.

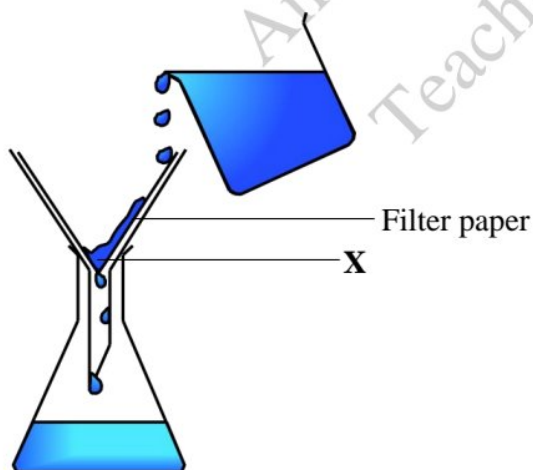

In the given setup, **X** that remains on the filter paper is identified as the

- A. filtrate.
- B. residue.
- C. crystals.
- D. precipitates.

43. If, in a mixture of sand and alum, we replace alum with sugar, then which of the following is the MOST appropriate sequence of steps to obtain pure sample of sugar?
- I. Dissolution
 - II. Filtration
 - III. Evaporation until dry
 - IV. Crystallisation
- A. I and III
 - B. I and IV
 - C. I, II and III
 - D. I, II and IV
44. For an experiment, Sarah used a bottle of sodium carbonate solution which had the label 'primary standard'. This label indicates that the sodium carbonate solution
- A. is hygroscopic in nature.
 - B. requires standardisation before its use.
 - C. is prepared from a secondary standard reagent.
 - D. has a strength which remains constant with time.

Use the given information to answer Q.45 and Q.46.

The given figures show two different ways of preparing copper sulphate crystals in the laboratory.

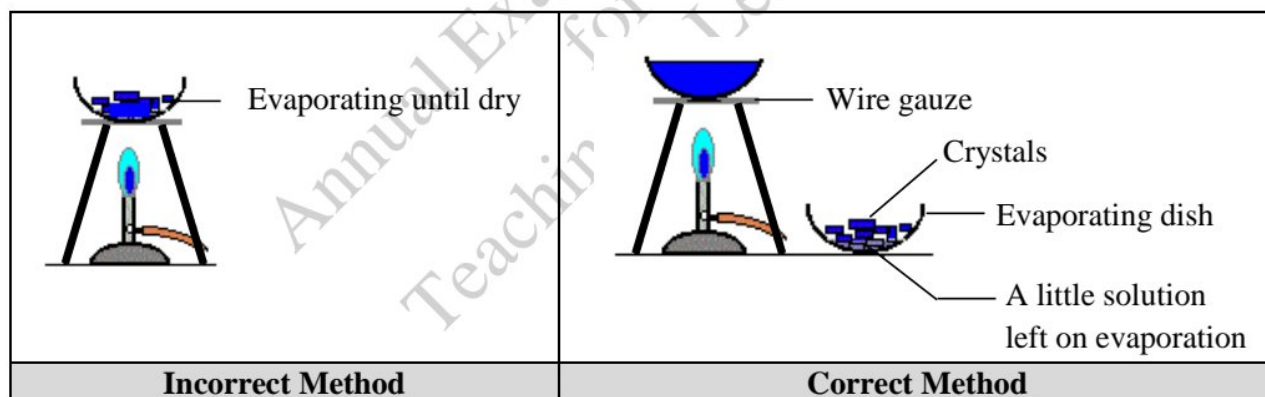

45. As shown in the figure, evaporating the solution in the china dish until it is dry is an incorrect method because
- A. blue crystals of copper sulphate are formed in uneven shapes and sizes.
 - B. blue crystals of copper sulphate decompose into dull white-grey powder.
 - C. solubility of copper sulphate in water increases with the rise in temperature.
 - D. solubility of copper sulphate in water decreases with the decrease in temperature.
46. Once the crystals start forming, heating is stopped, and the solution is left undisturbed to be cooled slowly (refer the figure for correct method). This slow crystallisation is essential as it facilitates in yielding
- A. deep violet crystals.
 - B. larger, highly pure crystals.
 - C. smaller, needle like crystals.
 - D. florescent greyish blue crystals.

PLEASE TURN OVER THE PAGE

47. Copper sulphate is highly soluble in water at a high temperature, whereas its solubility in water decreases appreciably at low temperatures. This difference in solubility is utilised in the laboratory to get the crystals of copper sulphate from its solution.

Based on this information, crystallisation can be inferred as a process of

- A. purifying substances.
 - B. increasing solubility.
 - C. decreasing solubility.
 - D. identifying substances.
48. A student is expected to prepare 0.5 M solution of sodium carbonate in a 100 mL flask. The mass of sodium carbonate that he/ she would require to prepare the desired solution is

(Note: $^{23}_{11}\text{Na}$, $^{12}_6\text{C}$ and $^{16}_8\text{O}$)

- A. 0.53 g.
 - B. 2.55 g.
 - C. 5.3 g.
 - D. 50 g.
49. The MAIN purpose of the method shown in the given picture is to

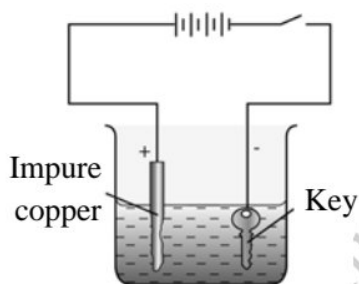

- A. purify the key.
 - B. make the key tensile.
 - C. save the key from corrosion.
 - D. increase the thickness of the key.
50. During the process of electroplating, electrodes made of metals are used because they primarily support the flow of
- A. ions.
 - B. volts.
 - C. atoms.
 - D. electrons.

**AGA KHAN UNIVERSITY EXAMINATION BOARD
SECONDARY SCHOOL CERTIFICATE**

CLASS IX

ANNUAL EXAMINATIONS 2022

Chemistry

Total Time: 1 hour 40 minutes

Total Marks: 50 (40-Theory & 10-Alternate to Practical)

INSTRUCTIONS

1. Read each question carefully.
2. Answer the questions on the separate answer sheet provided. DO NOT write your answers on the question paper.
3. There are 100 answer numbers on the answer sheet. Use answer numbers 1 to 50 only.
4. Question Distribution:

Theory	Alternate to Practical (ATP)
40 MCQs	10 MCQs

5. In each question, there are four choices A, B, C, D. Choose ONE. On the answer grid, black out the circle for your choice with a pencil as shown below.

Correct Way	Incorrect Ways
1 (A) (B) ● (D)	1 (A) (B) (C) (D)
	2 (A) (B) (C) (D)
	3 (A) (B) (C) (D)
	4 (A) (B) (C) (D)

Candidate's Signature

6. If you want to change your answer, ERASE the first answer completely with a rubber, before blacking out a new circle.
7. DO NOT write anything in the answer grid. The computer only records what is in the circles.
8. The marks obtained on the 40 MCQs will be equated to the total marks of 65 for the theory examination results.
9. You may use a simple calculator if you wish.

THEORY (Questions 1-40)

1. The formula of an ionic compound containing a metal ion (M^{+3}) and a non-metal ion (X^{-1}) is
- $3MX$.
 - M_3X .
 - MX_3 .
 - M_3X_3 .
2. Which of the following is NOT an empirical formula?
- CH_2
 - CH_2O
 - $C_2H_4N_2$
 - $C_3H_6O_2$
3. A sample of hydrocarbon undergoes complete combustion to produce carbon dioxide (CO_2) and water (H_2O).

(Note: Atomic mass of C = 12 amu, O = 16 amu and H = 1 amu)

If 8.80 g of carbon dioxide is obtained, then what will be the mass of carbon present in it?

- 2.4 g
 - 3.8 g
 - 12.0 g
 - 32.3 g
4. The values of w , x , y and z in the given chemical equation are

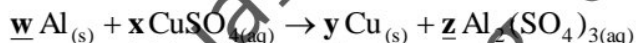

	w	x	y	z
A	2	1	1	2
B	2	2	2	1
C	2	3	3	1
D	3	2	2	1

5. Which type of chemical reaction is shown in the given equation?

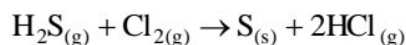

- Combustion
- Decomposition
- Single displacement
- Double displacement

6. The reactants of a double displacement reaction are
- two elements.
 - two ionic compounds.
 - two diatomic molecules.
 - an element and an ionic compound.
7. Which of the following actions will result in a combustion reaction?
- Freezing a juice bottle
 - Lighting a scented candle
 - Cutting an apple into slices
 - Mixing iron filings with sand
8. Deuterium and tritium are atoms of the same element, i.e. hydrogen. They both have the same
- atomic mass
 - atomic number
 - number of neutrons
 - number of electrons
- I and II.
 - I and III.
 - II and IV.
 - III and IV.
9. If an element has 3 electrons in its valence (M) shell, then what will be its atomic number?
- 15
 - 13
 - 10
 - 5
10. How many electrons, protons and neutrons are there in a nitrogen (${}^{14}_{7}\text{N}^{-3}$) ion?

	Number of Electrons	Number of Protons	Number of Neutrons
A	4	7	10
B	7	7	7
C	10	7	7
D	17	14	7

11. The electronic configuration provides information about all of the following features of an atom EXCEPT the
- group and the period it belongs to.
 - type of chemical bond it can form.
 - presence of neutrons in the nucleus.
 - distribution of electrons in different shells.
12. According to Rutherford atomic model, the nucleus in an atom is
- large and hard.
 - small and dense.
 - neutral and hollow.
 - light and revolving.
13. In nuclear reactors, the radioactive isotope used to produce energy is
- cobalt-60.
 - iodine-131.
 - strontium-90.
 - uranium-235.
14. Given are the characteristics of an element X.
- A salt former
 - Found in liquid state
 - Reddish brown in colour
 - Exists as a diatomic molecule
- The element X identified is
- sodium.
 - chlorine.
 - bromine.
 - beryllium.
15. The electronic configuration of an element of group IIA and period 3 is
- $1s^2, 2s^1$
 - $1s^2, 2s^2, 2p^1$
 - $1s^2, 2s^2, 2p^3$
 - $1s^2, 2s^2, 2p^6, 3s^2$
16. With reference to the different groups of the modern periodic table, the information that stands CORRECT is that all the elements in group
- 13 are metals.
 - 16 form $2+$ cations.
 - 17 produce basic oxides.
 - 18 exist in gaseous state.

17. When an atom **M** combines with another atom **X**, an ionic bond is formed. In this reaction, the atomic radius of the atom **X** increases because
- it loses electrons to atom **M**.
 - it gains electrons from atom **M**.
 - its protons get tightly packed inside the nucleus.
 - its ionisation energy increases on forming the ionic bond.
18. The quantity of energy that an isolated, gaseous atom in the ground electronic state must absorb to discharge an electron is termed as
- kinetic energy.
 - shielding effect.
 - electron affinity.
 - ionisation energy.
19. The given ion is formed from an element belonging to group

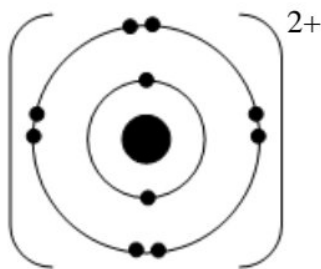

- IIA.
 - IVA.
 - VIA.
 - VIIIA.
20. The ionic compound whose both ions represent the same electronic configuration as that of neon atom (${}^{20}_{10}\text{Ne}$) is
- (Note: ${}^{24}_{12}\text{Mg}$, ${}^{39}_{19}\text{K}$, ${}^{35}_{17}\text{Cl}$ and ${}^{16}_{8}\text{O}$)
- K_2O
 - KCl
 - MgO
 - MgCl_2
21. Which of these elements will gain an electron to form an anion?
- Boron
 - Argon
 - Lithium
 - Chlorine

22. The table shows information about species **P** and **Q**.

Species	Number of Protons	Number of Neutrons	Electronic Structure
P	8	8	2, 8
Q	16	16	2, 8, 8

Based on the given information, species **P** and **Q** are the

- A. atoms of inert gases.
 B. positively charged ions.
 C. negatively charged ions.
 D. isotopes of the same element.
23. Which of the following statements stands TRUE for the formation of lithium chloride?

(Note: ${}^7_3\text{Li}$ and ${}^{35}_{17}\text{Cl}$)

- A. A lithium atom gives an electron to the chlorine atom.
 B. A chlorine atom gives an electron to the lithium atom.
 C. A chlorine atom shares an electron with the lithium atom.
 D. A lithium atom accepts a pair of electrons from the chlorine atom.
24. Which set of property and examples TRUE for polar covalent compounds?

	Property	Example
A	Electrons are pulled equally by bonded atoms	CCl_4
B	Electrons are pulled unequally by bonded atoms	CCl_4
C	Electrons are pulled equally by bonded atoms	HCl
D	Electrons are pulled unequally by bonded atoms	HCl

25. A coordinate covalent bond is formed when
- A. one atom shares an electron pair with another atom.
 B. one atom loses electrons and the other atom acquires them.
 C. two like atoms share their unpaired electrons with each other.
 D. two unlike atoms share their unpaired electrons with each other.
26. Which type of attractive forces are present between I_2 molecules?
- A. Ionic bonding
 B. Dispersion forces
 C. Hydrogen bonding
 D. Dipole-dipole forces

27. The given figure exemplifies the process of

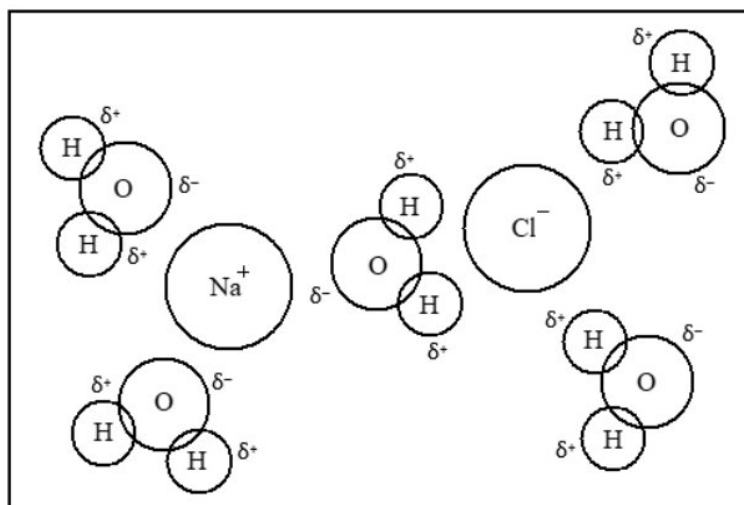

- A. dissolution.
- B. neutralisation.
- C. crystallisation.
- D. decomposition.

28. Bronze is an alloy consisting of 88% copper and 12% tin. Therefore, it is a solution of

- A. solid in solid.
- B. liquid in solid.
- C. solid in liquid.
- D. liquid in liquid.

29. A sugar solution is prepared by dissolving 10 g of sugar in 55 g of water.

The mass percent of solvent in the given solution is

- A. 15.38%.
- B. 18.18%.
- C. 81.82%.
- D. 84.62%.

30. Consider the given characteristics of the particles of a mixture.

- Large but cannot be seen with naked eyes
- Big but can pass through the filter paper
- Quite stable and do not settle down for a long time

The mixture to which these characteristics BEST fit is

- A. lemonade.
- B. soap lather.
- C. sand in water.
- D. milk of magnesia.

31. The given graph shows variation in the solubility of potassium nitrate and sodium chloride salts with temperature.

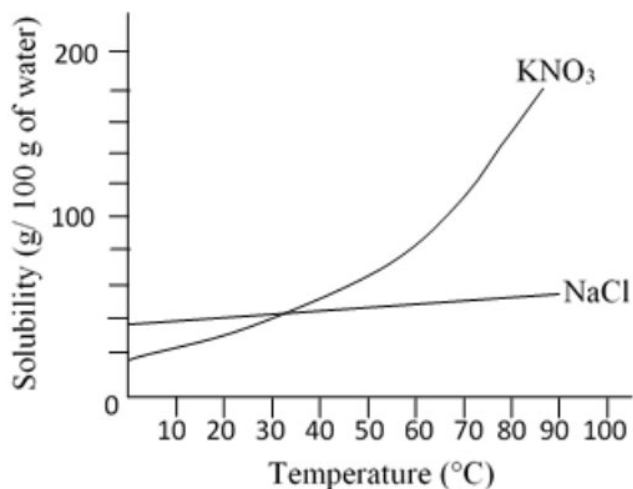

- The TRUE interpretation of the given graph is that, with the rise in temperature, the solubility of
- A. both salts increases with the release of heat.
 - B. both salts increases with the absorption of heat.
 - C. NaCl increases while that of KNO₃ shows loss of heat.
 - D. KNO₃ increases while that of NaCl shows no change in heat.
32. The method that can be used to investigate the presence of different food colours in a beverage is
- A. alloying.
 - B. crystallisation.
 - C. decomposition.
 - D. chromatography.
33. A mixture is formed when chalk is added to water. The particles in this mixture
- A. cannot be seen by the naked eye.
 - B. settle over time if left undisturbed.
 - C. have a diameter less than 1000 nm.
 - D. cannot be separated through filtration.
34. The term, 'oxidation' of a substance means
- A. gain of electron and loss of oxygen atom.
 - B. gain of oxygen atom and loss of electron.
 - C. gain of electron and loss of hydrogen atom.
 - D. gain of hydrogen atom and loss of electron.

35. The oxidation number of phosphorus in NaH_2PO_4 is
- 5
 - 3
 - + 3
 - + 5
36. Which substance gets reduced when a piece of magnesium is dipped into a copper(II) salt solution?
- Copper ions
 - Copper atoms
 - Magnesium ions
 - Magnesium atoms
37. Consider the given substances.
- Fe
 - FeCl_2
 - FeCl_3
- The substance(s) that can be used as a reducing agent is/ are
- I only.
 - I and II.
 - III only.
 - II and III.
38. Given are the properties of a solution.
- Does not conduct electricity
 - Solute is dissolved completely
 - Solute is not dissociated into ions
- Based on the given properties, the solution identified is
- dilute solution of non-electrolyte.
 - dilute solution of strong electrolyte.
 - concentrated solution of weak electrolyte.
 - concentrated solution of strong electrolyte.
39. During the manufacturing process of caustic soda in Nelson's cell, the by-product that is obtained at anode is/ are
- chlorine gas.
 - hydrogen gas.
 - sodium metal.
 - water vapours.

40. The term, 'rusting' refers to the corrosion of

- A. iron.
- B. copper.
- C. chromium.
- D. aluminium.

ALTERNATE TO PRACTICAL (ATP: Questions 41-50)

41. A student used solvent **X** to separate a mixture of salt and sugar because sugar is soluble in **X** while salt is not.

Based on this information, the solvent **X** used by the student is

- A. oil.
- B. water.
- C. ethanol.
- D. acetic acid.

42. In a science laboratory, Mariam prepared a mixture of SiO_2 and $\text{K}_2\text{SO}_4 \cdot \text{Al}_2(\text{SO}_4)_3 \cdot 24\text{H}_2\text{O}$ in water. She then applied the process of filtration on the mixture.

An inference Mariam must have made through this experiment is that

- A. SiO_2 is insoluble in water.
- B. SiO_2 easily passes through the filter paper.
- C. $\text{K}_2\text{SO}_4 \cdot \text{Al}_2(\text{SO}_4)_3 \cdot 24\text{H}_2\text{O}$ is an amorphous solid.
- D. $\text{K}_2\text{SO}_4 \cdot \text{Al}_2(\text{SO}_4)_3 \cdot 24\text{H}_2\text{O}$ easily settles down in water.

43. A student accidentally dropped some iron filings in a bottle of sodium chloride.

Which step(s) should he/ she follow to remove the iron filings?

- A. Use a magnet only
- B. Dissolve the mixture in water and filter it
- C. Dissolve the mixture in water, filter it and crystallise the filtrate
- D. Use a magnet, dissolve the mixture in water, filter and evaporate it

44. When sucrose is dissolved in water, its solubility increases with the rise in temperature because sucrose

- A. evolves heat in water.
- B. ionises completely in water.
- C. absorbs heat from the water.
- D. reacts chemically with water.

45. Oxalic acid is a primary standard substance because of its high

- A. density.
- B. stability.
- C. solubility.
- D. reactivity.

46. In a laboratory, Altamash is provided with a 250 mL volumetric flask to prepare 0.1 M oxalic acid solution.

How much mass of oxalic acid ($\text{H}_2\text{C}_2\text{O}_4 \cdot 2\text{H}_2\text{O}$) does he require to accomplish his task?

(Note: $^{12}_6\text{C}$, ^1_1H and $^{16}_8\text{O}$)

- A. 2.25 g
- B. 3.15 g
- C. 25.0 g
- D. 50.4 g

Use the given information to answer Q.47 and Q.48.

The following steps are ensured when preparing crystals of pure copper sulphate ($\text{CuSO}_4 \cdot 5\text{H}_2\text{O}$) from an impure sample of blue vitriol.

- A few drops of dilute sulphuric acid are added to the aqueous solution of sample.
- The filtrate should be evaporated only up to the crystallisation point.

47. The purpose of adding dilute sulphuric acid is to

- A. breakdown copper sulphate into its ions.
- B. prevent the hydrolysis of copper sulphate.
- C. cause the decomposition of copper sulphate.
- D. remove impurities present in copper sulphate.

48. If heating is exceeded (beyond the crystallisation point) to dryness, then this causes

- I. disappearance of blue colour
- II. loss of water of crystallisation
- III. disappearance of the compound
- IV. loss of turbidity from the solution

- A. I and II.
- B. I and III.
- C. II and IV.
- D. III and IV.



49. Electroplating is a redox reaction that is performed to prevent iron from corrosion.

Considering this information, all of the following statements are true EXCEPT that this process involves the

- A. transfer of electrons between reactants.
- B. use of a salt bridge for the migration of ions.
- C. use of electrical energy to initiate the reaction.
- D. electrolyte of the same metal being coated on iron.

PLEASE TURN OVER THE PAGE

50. Consider the given table.

Electrolytic Cell			
	X	Y	Z
Observation of Bulb	No light	A dim light	A bright light

Based on the given observations, the electrolyte that would be MOST likely present in the electrolytic cells **X**, **Y** and **Z** are

	X	Y	Z
A	potassium chloride	sugar	acetic acid
B	sugar	ethanol	hydrochloric acid
C	acetic acid	hydrochloric acid	sugar
D	ethanol	acetic acid	potassium chloride

AGA KHAN UNIVERSITY EXAMINATION BOARD

SECONDARY SCHOOL CERTIFICATE

CLASS IX

ANNUAL EXAMINATIONS (THEORY) 2023

Chemistry Paper I

Time: 1 hour 10 minutes Marks: 40

INSTRUCTIONS

1. Read each question carefully.
2. Answer the questions on the separate answer sheet provided. DO NOT write your answers on the question paper.
3. There are 100 answer numbers on the answer sheet. Use answer numbers 1 to 40 only.
4. In each question there are four choices A, B, C, D. Choose ONE. On the answer grid black out the circle for your choice with a pencil as shown below.

Correct Way	Incorrect Ways
1 (A) (B) ● (D)	1 (A) (B) (C) (D)
	2 (A) (B) (C) (D)
	3 (A) (B) (C) (D)
	4 (A) (B) (C) (D)

Candidate's Signature

5. If you want to change your answer, ERASE the first answer completely with a rubber, before blacking out a new circle.
6. DO NOT write anything in the answer grid. The computer only records what is in the circles.
7. You may use a simple calculator if you wish.

1. The investigation of chemical changes in diseases, drug action and nutrition is carried out by a/ an
- A. biochemist.
 - B. physical chemist.
 - C. industrial chemist.
 - D. inorganic chemist.

2. In $\text{Ca}_3(\text{PO}_4)_2$, the valencies of calcium and phosphate ions respectively are

	Valency of	
	Calcium Ion	Phosphate Ion
A	3	2
B	3	4
C	2	3
D	2	4

3. The mass of 2.5 moles of H_2O is

(Note: $^{16}_8\text{O}$ and ^1_1H)

- A. 45.0 g.
 - B. 42.5 g.
 - C. 20.5 g.
 - D. 18.0 g.
4. The number of molecules in 2.1 moles of carbon dioxide is

(Note: $^{16}_8\text{O}$ and $^{12}_6\text{C}$)

- A. 2.87×10^{22}
 - B. 2.87×10^{23}
 - C. 1.26×10^{24}
 - D. 1.26×10^{25}
5. A phenomenon that ALWAYS occurs in a chemical reaction is that it
- A. liberates a gas.
 - B. produces precipitates.
 - C. forms a new substance.
 - D. shows a change in colour.
6. Nichrome is prepared by combining
- A. nickel and copper.
 - B. iron and chromium.
 - C. iron, nickel and copper.
 - D. iron, nickel and chromium.

7. Which of the following is a diluted solution?

(Note: Molar mass of $\text{HNO}_3 = 63 \text{ g/mol}$, $\text{NaOH} = 40 \text{ g/mol}$, $\text{H}_2\text{SO}_4 = 98 \text{ g/mol}$, $\text{Ca(OH)}_2 = 74 \text{ g/mol}$)

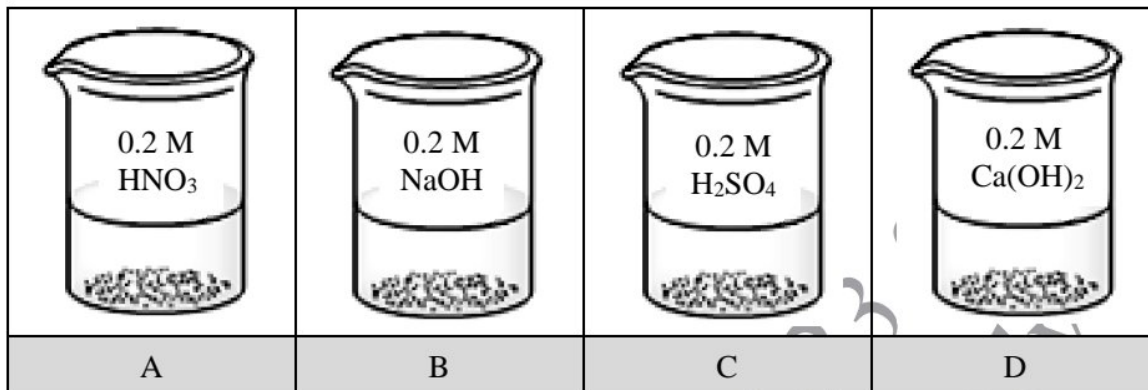

8. The concentration of a solution containing 53 g of Na_2CO_3 in 1 dm^3 is

(Note: $^{23}_{11}\text{Na}$, $^{16}_8\text{O}$ and $^{12}_6\text{C}$)

- A. 0.5 M.
 B. 0.96 M.
 C. 1.03 M.
 D. 2 M.
9. The technique that CANNOT separate the components of a homogeneous mixture is
- A. filtration.
 B. distillation.
 C. crystallisation.
 D. chromatography.
10. A true solution is a homogeneous mixture of two or more substances.
 Based on this information, which of the following is an example of a true solution?
- A. Fog
 B. Blood
 C. Sugar syrup
 D. Whipped cream
11. The loss or gain of a particle that does NOT affect the mass of an atom is a/ an
- A. proton.
 B. neutron.
 C. electron.
 D. alpha particle.

12. An ion Y^+ has 39 nucleons and 18 electrons.

The number of protons and neutrons that the nucleus of this ion contains is

	Number of Protons	Number of Neutrons
A	20	19
B	19	20
C	21	18
D	18	21

13. How many nucleons are present in an isotope of carbon ($^{13}_6\text{C}$) ?

- A. 13
- B. 12
- C. 7
- D. 6

14. The limitation of Rutherford atomic model is that the

- A. mass and charge of an atom is concentrated in the nucleus.
- B. positively charged nucleus resides in the centre of the atom.
- C. electrons revolve around the nucleus at a high speed in fixed orbits.
- D. revolving electrons continuously loose energy and fall on the nucleus.

15. The electronic configuration of aluminium ion in aluminium oxide, Al_2O_3 , is

(Note: $^{27}_{13}\text{Al}$)

- A. $1s^2 2s^2 2p^6$
- B. $1s^2 2s^2 2p^6 3s^1$
- C. $1s^2 2s^2 2p^6 3s^2 3p^1$
- D. $1s^2 2s^2 2p^6 3s^2 3p^2$

16. The STRONGEST oxidising ability among halogens is possessed by

- A. fluorine.
- B. chlorine.
- C. bromine.
- D. iodine.

17. The general electronic configuration of $ns^2 np^3$ indicates that the element belongs to

- A. period 3.
- B. period 5.
- C. group VA.
- D. group IIIA.

18. Consider the given characteristics of a group of elements.

- Soft
- Low melting point
- Highly electropositive

Based on these characteristics, the group of elements is identified as

- A. halogens.
- B. alkali metals.
- C. carbon family.
- D. oxygen family.

19. The number of shells in the atomic structure of an element represents

- A. its ionisation potential.
- B. the group it belongs to.
- C. the period it belongs to.
- D. its electrical conductivity.

20. The term, 'electronegativity' is described as the ability of an atom to

- A. act as an oxidising agent.
- B. accept an electron from another atom.
- C. attract shared paired of electrons to itself.
- D. absorb maximum energy to lose an electron.

21. Water vapours have a lower density than ice because in water vapours the particles have

- A. orderly arrangement.
- B. vibrational movement.
- C. very low kinetic energy.
- D. very weak attractive forces.

22. In a closed system, a change in kinetic energy of particles causes the substance to change its

- A. state.
- B. mass.
- C. volume.
- D. boiling point.

23. During extremely cold weather when the temperature is -20°C , a room's temperature is maintained at $+20^{\circ}\text{C}$ with 60% internal humidity.

Under the given conditions, the formation of water drops and ice on the interior of window of the room is the result of

- A. sublimation.
- B. evaporation.
- C. precipitation.
- D. condensation.

PLEASE TURN OVER THE PAGE

24. The term, 'allotrope' describes the difference in elements based on their
- structural forms.
 - number of H^+ ions.
 - number of neutrons.
 - phases (solid, liquid or gas).
25. In industries, graphite is used as a/ an
- electrode.
 - ornament.
 - electrolyte.
 - cutting tool.
26. The compound that possesses ionic bond between its atoms is
- CS_2
 - CCl_4
 - HCN
 - MgF_2
27. Chlorine belongs to group VIIA and beryllium belongs to group IIA of the modern periodic table.
- In a reaction between chlorine and beryllium, each atom of chlorine
- gives an electron to an atom of beryllium.
 - shares an electron with an atom of beryllium.
 - accepts an electron from an atom of beryllium.
 - shares an electron pair with an atom of beryllium.
28. Hydrogen can form an ionic compound with
- carbon.
 - sodium.
 - fluorine.
 - nitrogen
29. HCl is a polar covalent compound showing all of the following properties EXCEPT that it
- is soluble in water.
 - ionises completely in aqueous medium.
 - has partial positive and negative charges.
 - shows electronegativity difference as zero.

30. In the given structure, the four species **X** are connected to carbon by **Y** bonds.

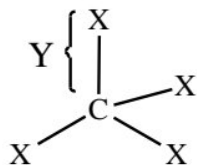

The species **X** and **Y** bonds are identified as

	Species X	Y Bonds
A	atoms	weak
B	atoms	strong
C	ions	weak
D	ions	strong

31. The oxidation state of chromium in CrO_3 is

- A. -6
- B. -3
- C. +3
- D. +6

32. Samra uses the following setup to test the conductivity of an electrolyte.

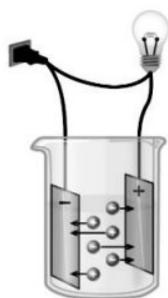

The illustration shows high conductivity of the electrolyte. This indicates that the substance she must have used is

- A. petrol.
 - B. glucose.
 - C. lithium fluoride.
 - D. carbon tetrachloride.
33. Metal electrodes are good conductors of electricity because they
- A. contain partial charges.
 - B. are highly electronegative.
 - C. are connected to the battery.
 - D. contain delocalised electrons.

PLEASE TURN OVER THE PAGE

34. A voltaic (galvanic) cell is an electrochemical cell which
- converts electrical energy into chemical energy.
 - generates electricity through spontaneous redox reaction.
 - comprises of two electrodes made up of the same inert metal.
 - consists of a positively charged anode and a negatively charged cathode.
35. The following diagram shows an electrolytic cell used for electroplating iron with chromium.

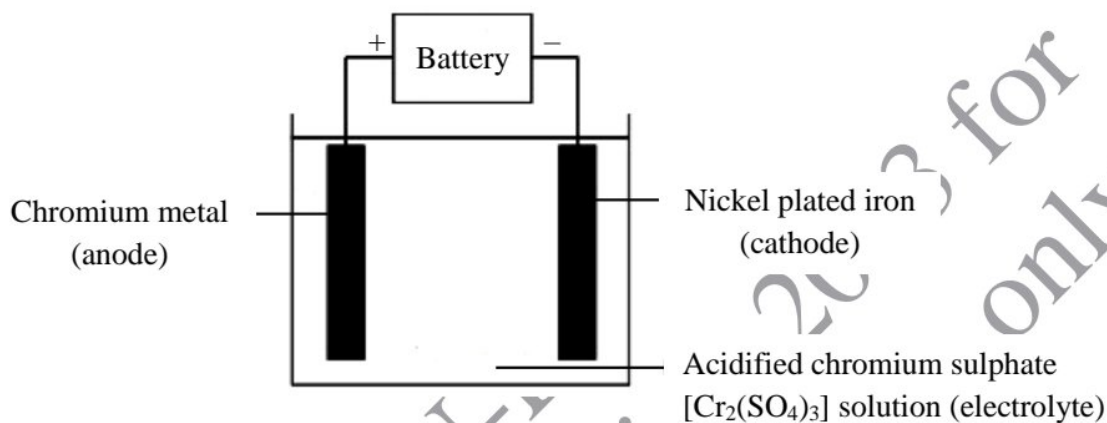

The chemical reaction that takes place at cathode is

- $\text{Cr}_{(s)} \rightarrow \text{Cr}_{(aq)}^{2+} + 2e^{-}$
 - $\text{Cr}_{(aq)}^{2+} + 2e^{-} \rightarrow \text{Cr}_{(s)}$
 - $\text{Cr}_{(s)} \rightarrow \text{Cr}_{(aq)}^{3+} + 3e^{-}$
 - $\text{Cr}_{(aq)}^{3+} + 3e^{-} \rightarrow \text{Cr}_{(s)}$
36. For an experiment, Asad used a metal oxide, which can act as either an acid or a base to produce salt and water.
- The metal oxide used by him is
- SiO₂
 - CaO
 - Li₂O
 - Al₂O₃
37. Amongst the given group I elements, the first ionisation energy would be the HIGHEST for
- lithium.
 - sodium.
 - rubidium.
 - potassium.

38. In contrast to sodium, iron is a hard metal because it

- A. requires greater energy to break.
- B. has weaker metallic bonding.
- C. belongs to group IIA.
- D. is highly reactive.

39. Consider the given characteristics.

- Solid
- Brittle
- Non-lustrous

The element described by these characteristics is

- A. carbon.
- B. copper.
- C. oxygen.
- D. aluminium.

40. The elements of group IIA are known as

- A. noble metals.
- B. alkali metals.
- C. transition metals.
- D. alkaline earth metals.

AKU-EB
Annual Examination 2023 for
Teaching and Learning only

AGA KHAN UNIVERSITY EXAMINATION BOARD

SECONDARY SCHOOL CERTIFICATE

CLASS IX

ANNUAL EXAMINATIONS (THEORY) 2024

Chemistry Paper I

Time: 1 hour 10 minutes Marks: 40

INSTRUCTIONS

1. Read each question carefully.
2. Answer the questions on the separate answer sheet provided. DO NOT write your answers on the question paper.
3. There are 100 answer numbers on the answer sheet. Use answer numbers 1 to 40 only.
4. In each question there are four choices A, B, C, D. Choose ONE. On the answer grid black out the circle for your choice with a pencil as shown below.

Correct Way				Incorrect Ways			
1	<input type="radio"/>	<input type="radio"/>	<input checked="" type="radio"/>	<input type="radio"/>	<input type="radio"/>	<input checked="" type="radio"/>	<input type="radio"/>
	<input type="radio"/>	<input type="radio"/>	<input checked="" type="radio"/>	<input type="radio"/>	<input type="radio"/>	<input checked="" type="radio"/>	<input type="radio"/>
	<input type="radio"/>	<input type="radio"/>	<input checked="" type="radio"/>	<input type="radio"/>	<input type="radio"/>	<input checked="" type="radio"/>	<input type="radio"/>
	<input type="radio"/>	<input type="radio"/>	<input checked="" type="radio"/>	<input type="radio"/>	<input type="radio"/>	<input checked="" type="radio"/>	<input type="radio"/>

Candidate's Signature

5. If you want to change your answer, ERASE the first answer completely with a rubber, before blacking out a new circle.
6. DO NOT write anything in the answer grid. The computer only records what is in the circles.
7. You may use a simple calculator if you wish.

- The branch of chemistry that deals with the study of producing valuable materials in significant quantities by manipulating the raw materials is
 - analytical chemistry.
 - industrial chemistry.
 - physical chemistry.
 - nuclear chemistry.
- Which of the following examples represents a type of chemical reaction?
 - Melting of ice cream
 - Dissolution of sugar in water
 - Vapourisation of ethyl alcohol
 - Mixing of baking soda and vinegar
- Which of the following options shows the CORRECT classification of substances in the given table?

	Element	Mixture	Compound
A	Brass	Carbon	Ammonium Chloride
B	Carbon	Ammonium Chloride	Brass
C	Ammonium Chloride	Brass	Carbon
D	Carbon	Brass	Ammonium Chloride

- A compound **X** has an empirical formula C_3H_3O and its molecular mass is 110. Which of the following represents the molecular formula of compound **X**?
 - CHO
 - $C_3H_3O_3$
 - C_6H_6O
 - $C_6H_6O_2$
- In humans and other animals, starch is broken down into its constituent sugar molecules through the process of
 - synthesis.
 - hydrolysis.
 - displacement.
 - condensation.
- A gaseous solution is formed when
 - copper combines with tin.
 - ammonia dissolves in water.
 - naphthalene ball sublimates in air.
 - iron amalgamates with chromium.

10. The molarity of the given sodium hydroxide solution will be

(Note: Atomic mass of Na = 23 amu, O = 16 amu, H = 1 amu)



15.8 g NaOH

- A. 0.03 M.
B. 0.19 M.
C. 0.79 M.
D. 1.26 M.
11. A metal compound has the formula XCl_2 and a relative formula mass of 95.211.
The relative atomic mass of X is
(Note: $^{35.5}_{17}Cl$)
A. 24.211
B. 59.711
C. 61.211
D. 78.211
12. How many protons are present in an ion with atomic number 8, mass number 16 and a 2- charge?
A. 06
B. 08
C. 14
D. 16
13. Each p sub-shell can hold a maximum number of
A. 2 electrons.
B. 3 electrons.
C. 6 electrons.
D. 8 electrons.
14. Uranium has two isotopes, ^{235}U and ^{238}U . ^{238}U differs from ^{235}U by having 3 more
A. protons.
B. neutrons.
C. protons and electrons.
D. neutrons and electrons.

15. In Rutherford's experiment, when α -particles are passed through a thin metal foil, most of them go straight through the foil because of the
- repulsion of protons.
 - empty spaces in an atom.
 - high speed of α -particles.
 - negative charge of electrons.
16. Neon and argon are classified as noble gases because they have
- coloured vapours.
 - same atomic number.
 - non-metallic character.
 - full outer electron shell.
17. Consider the given dot and cross diagram representing the valence shell electrons of the bonded elements.

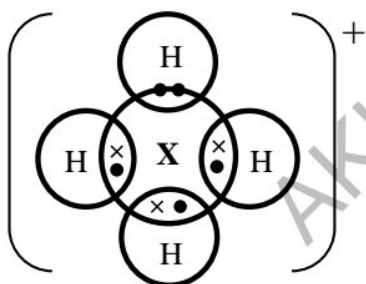

Which group of the modern periodic table does the element X belong to?

- IA
 - IIIA
 - VA
 - VIA
18. Given is the electronic configuration of an element.



Which block of the periodic table does the element belong to?

- s
- p
- d
- f

19. Which of the TWO given elements belong to the same group of the modern periodic table?

I	Phosphorus (2, 8, 5)	II	Silicon (2, 8, 4)
III	Nitrogen (2, 5)	IV	Oxygen (2, 6)

- A. I and II
 B. I and III
 C. II and IV
 D. III and IV
20. Metallic character of elements depends on their ability to

- A. form anions.
 B. show low density.
 C. lose valence electrons.
 D. attract shared electrons.

21. A substance **X** has the following characteristics.

- I. Indefinite shape and volume
 II. Can easily be compressed

The substance **X** could be identified as

- A. steam.
 B. coffee.
 C. mercury.
 D. table salt.
22. Some of the gases with their relative molecular masses are given in the table below.

I	Helium	4
II	Ethene	28
III	Methane	16
IV	Chlorine	71
V	Oxygen	32

Which option shows the CORRECT sequence of gases according to their rates of diffusion, i.e., from fastest to slowest?

- A. I, III, II, V, IV
 B. II, III, IV, V, I
 C. III, V, I, II, IV
 D. IV, V, II, III, I

23. When rubbing alcohol is applied on a cut, it feels cold on the skin because of the process of
- condensation.
 - sublimation.
 - evaporation.
 - freezing.

24. When few drops of ink are added in water, they slowly start to disperse. This spreading of molecules can be enhanced by increasing temperature.

What will be the impact on the molecules when the temperature is increased?

- Velocity of the molecules will increase.
 - Pressure on the molecules will decrease.
 - Intermolecular forces of attraction will increase.
 - Volume occupied by the molecules will decrease.
25. Plastic and rubber are the examples of amorphous solids because they
- show a regular three-dimensional geometry.
 - exhibit the phenomenon of anisotropy.
 - melt over a wide range of temperature.
 - possess definite cleavage planes.
26. The ion of which of these elements will have the same number of electrons as an atom of neon (${}^{20}_{10}\text{Ne}$)?
- ${}^7_3\text{Li}$
 - ${}^9_4\text{Be}$
 - ${}^{24}_{12}\text{Mg}$
 - ${}^{39}_{19}\text{K}$
27. The given table shows the electronic structures of two different elements.

Element X	2, 8, 8, 2
Element Y	2, 8, 6

What will be the type and formula of the compound formed when elements X and Y react together?

	Type of Compound	Formula
A	Ionic Compound	XY
B	Ionic Compound	XY ₂
C	Covalent Compound	X ₂ Y
D	Covalent Compound	X ₂ Y ₂

PLEASE TURN OVER THE PAGE

28. Consider the given pairs of elements.

- I. Hydrogen and potassium
- II. Oxygen and potassium
- III. Hydrogen and carbon
- IV. Oxygen and carbon

Which pairs of elements can form covalent bonds when they react with each other?

- A. I and II
- B. I and III
- C. II and IV
- D. III and IV

29. A polar covalent compound is formed, when one atom of

- A. sulphur combines with two atoms of oxygen.
- B. carbon combines with four atoms of chlorine.
- C. sulphur combines with three atoms of oxygen.
- D. carbon combines with four atoms of hydrogen.

30. Which of the following bonds is present between copper atoms that allows copper to conduct electricity?

- A. Ionic bond
- B. Metallic bond
- C. Covalent bond
- D. Co-ordinate covalent bond

31. Reduction is defined as a chemical process which involves

- A. loss of electrons.
- B. addition of oxygen.
- C. removal of hydrogen.
- D. decrease in oxidation state.

32. The reaction between hydrogen and black copper(II) oxide is written as follows:

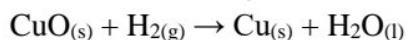

In this reaction, which substance is oxidised?

- A. $\text{H}_{2(g)}$
- B. $\text{Cu}_{(s)}$
- C. $\text{H}_2\text{O}_{(l)}$
- D. $\text{CuO}_{(s)}$

33. The oxidation state of chlorine in ClO_3^- is
- +1
 - +3
 - +5
 - +7
34. A voltaic (galvanic) cell is an electrochemical cell which
- converts electrical energy into chemical energy.
 - generates electricity through spontaneous redox reaction.
 - comprises of two electrodes made up of the same inert metal.
 - consists of a positively charged anode and a negatively charged cathode.
35. Galvanising is one of the methods to prevent iron from rusting. This method involves coating of iron with a protective layer of
- tin.
 - zinc.
 - aluminium.
 - magnesium.
36. A metallic anchor is used to prevent ships from drifting due to wind or ocean current. Anchors are often made up of iron because it
- is sonorous.
 - is unreactive.
 - has high density.
 - has low melting point.
37. All of the following metals exist in combined state in nature EXCEPT
- magnesium.
 - aluminium.
 - platinum.
 - sodium.
38. A carbonate of metal **X** has the following characteristics.
- White, odourless powder
 - Insoluble in water
 - Decomposes into lime and carbon dioxide
- The metal **X** can be identified as
- sodium.
 - calcium.
 - platinum.
 - magnesium.

PLEASE TURN OVER THE PAGE

39. An element **X** exists as a diatomic gas at room temperature. Each atom of element **X** requires one electron to form a stable X^{-1} ion.

Based on the given information, the element **X** is a/ an

- A. alkaline earth metal.
 - B. alkali metal.
 - C. inert metal.
 - D. non-metal.
40. Halogens react with hydrogen gas to produce hydrogen halides that are water soluble gases.

When dissolved in water, all of these gases produce strong acids EXCEPT

- A. hydrogen bromide.
- B. hydrogen chloride.
- C. hydrogen fluoride.
- D. hydrogen iodide.

AKU-EB
Annual Examinations 2024
for Teaching & Learning only

END OF PAPER

AGA KHAN UNIVERSITY EXAMINATION BOARD

SECONDARY SCHOOL CERTIFICATE

CLASS IX

ANNUAL EXAMINATIONS (THEORY) 2025

Chemistry Paper I

Time: 1 hour 10 minutes Marks: 40

INSTRUCTIONS

1. Read each question carefully.
2. Answer the questions on the separate answer sheet provided. DO NOT write your answers on the question paper.
3. There are 100 answer numbers on the answer sheet. Use answer numbers 1 to 40 only.
4. In each question there are four choices A, B, C, D. Choose ONE. On the answer grid black out the circle for your choice with a pencil as shown below.

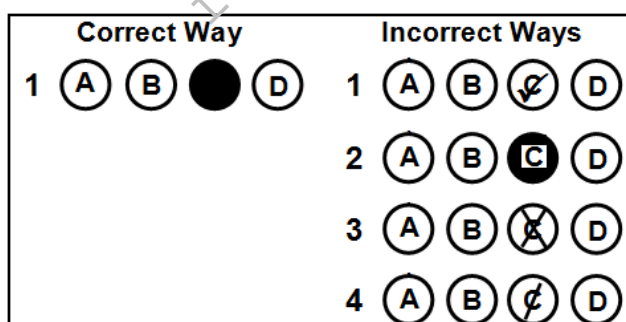

Candidate's Signature

5. If you want to change your answer, ERASE the first answer completely with a rubber, before blacking out a new circle.
6. DO NOT write anything in the answer grid. The computer only records what is in the circles.
7. You may use a simple calculator if you wish.

1. Ozone (O_3) is a highly reactive gas which is formed in the stratosphere with the help of ultraviolet radiations.

If 10.5 moles of ozone gas is formed in the stratosphere, then its mass in grams will be

(Note: $^{16}_8O$)

- A. 84
 B. 168
 C. 252
 D. 504
2. Which of the following pairs of substances represents pure compounds?

	Substance I	Substance II
A	Air	Water
B	Ammonia	Water
C	Air	Sea water
D	Ammonia	Sea water

3. The ions/ radicals in each of the given compounds have a valency of 2 EXCEPT

- A. NH_3
 B. BeO
 C. $CaSO_4$
 D. $MgCO_3$

4. A compound contains 40% carbon, 6.7% hydrogen and 53.3% oxygen by mass.

Based on the given information, the empirical formula of this compound is

(Note: 1_1H , $^{12}_6C$ and $^{16}_8O$)

- A. CH_2O
 B. CH_2O_2
 C. C_2H_4O
 D. $C_3H_6O_3$
5. The equation that exemplifies single displacement reaction is
- A. $CaO_{(s)} + H_2O_{(l)} \rightarrow Ca(OH)_{2(aq)}$
 B. $CuSO_{4(aq)} + Zn_{(s)} \rightarrow ZnSO_{4(aq)} + Cu_{(s)}$
 C. $H_2SO_{4(aq)} + 2NH_{3(g)} \rightarrow (NH_4)_2SO_{4(aq)}$
 D. $2AgNO_{3(aq)} + BaCl_{2(aq)} \rightarrow 2AgCl_{(s)} + Ba(NO_3)_{2(aq)}$

6. Which of the following statements defines a solution?
- A. A pure compound having one or more solutes dissolved in a solvent
 - B. A homogeneous mixture having one or more solutes dissolved in a solvent
 - C. A heterogeneous mixture having one or more solutes dissolved in a solvent
 - D. A pure compound having a solute and a solvent mixed in a fixed ratio by mass

7. A sugar solution is prepared by dissolving 10 g of sugar in 55 g of water.

The mass percent of solvent (water) in the given solution is

- A. 15.38%.
 - B. 18.18%.
 - C. 81.82%.
 - D. 84.62%.
8. Azfer was asked to prepare 0.1 M oxalic acid solution using 3.15 g of oxalic acid in a 250 mL volumetric flask. The lab assistant provided Azfer with a 500 mL flask instead of 250 mL for the same amount of oxalic acid.

What will be the molarity of the solution in the 500 mL flask?

(**Note:** The molar mass of oxalic acid is 126 g mol^{-1} .)

- A. 0.05 M
 - B. 0.07 M
 - C. 0.10 M
 - D. 0.14 M
9. All of the following factors affect the solubility of a solid solute in a solvent EXCEPT
- A. polarity.
 - B. pressure.
 - C. temperature.
 - D. surface area.
10. When dissolved in water, the substance that forms a suspension is
- A. milk.
 - B. alcohol.
 - C. sodium chloride.
 - D. calcium carbonate.
11. The species that does NOT carry an electrical charge is a/ an
- A. anion.
 - B. cation.
 - C. proton.
 - D. neutron.

PLEASE TURN OVER THE PAGE

12. How many protons, neutrons and electrons are present in Be^{2+} ion?

(Note: ${}^9_4\text{Be}$)

	Number of		
	Protons	Neutrons	Electrons
A	4	9	2
B	5	4	3
C	4	5	2
D	5	9	3

13. The commonly used isotope as fuel for nuclear power plants and the nuclear reactors that run naval ships and submarines is

- A. cobalt-60
- B. iodine-131
- C. strontium-90
- D. uranium-235

14. Rutherford's gold metal foil experiment proved that the mass and charge of an atom is concentrated in its

- A. orbits.
- B. protons.
- C. nucleus.
- D. electrons.

15. The incompletely filled electronic sub-shell in case of potassium (${}^{39}_{19}\text{K}$) is

- A. 3s.
- B. 3p.
- C. 4s.
- D. 4p.

16. The given dot and cross structure shows valence shell electrons of element **X** and hydrogen.

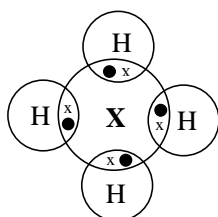

The group of the periodic table to which element **X** belongs is

- A. IVA.
- B. VA.
- C. VIA.
- D. VIIIA.

17. The following table shows the difference between all the elements of **X** and **Y** families.

Property	X	Y
Reactivity	Unreactive	Reactive
Occurrence	Monoatomic	Diatomic

With reference to the given table, **X** and **Y** families can be identified as

	X	Y
A	noble gases	oxygen group
B	alkali metals	halogens
C	noble gases	halogens
D	alkali metals	oxygen group

18. A metallurgical engineer intends to utilise a group of specific elements exhibiting the following characteristics.

- Soft
- Low melting point
- Highly electropositive

Based on the given characteristics, he would MOST likely use the elements belonging to which block of the periodic table?

- A. s-block
 B. p-block
 C. d-block
 D. f-block
19. A TRUE statement regarding the electronegativity of elements is that
- A. electronegativity value of fluorine is lower than that of chlorine.
 B. electronegativity value of alkali metals is higher than that of alkaline earth metals.
 C. it is the amount of energy required to remove an electron from a gaseous atom or ion.
 D. it is the tendency of an atom in a molecule to attract the shared pair of electrons to itself.
20. A decrease in attraction between the outer electrons and the nucleus of an atom due to the blocking effect of the inner electrons is termed as
- A. shielding effect.
 B. electron affinity.
 C. electronegativity.
 D. ionisation potential.

PLEASE TURN OVER THE PAGE

21. The given diagram shows the process of

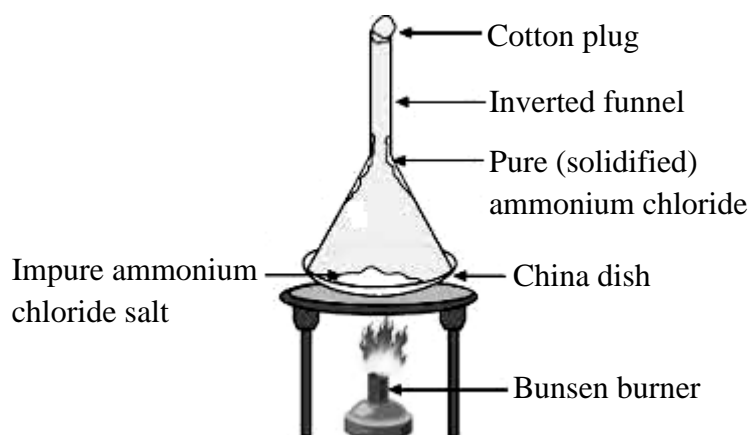

- A. boiling.
 B. melting.
 C. sublimation.
 D. condensation.
22. What happens when 1 mole of a gas expands at a constant temperature?
- A. The pressure of the gas decreases
 B. The number of molecules of the gas increases
 C. The intermolecular force of attraction increases
 D. The kinetic energy of the gas molecules decreases
23. The property of a gas that is measured in g/cm^3 is
- A. mass.
 B. density.
 C. volume.
 D. pressure.
24. The option that shows the CORRECT relationship among intermolecular forces, vapour pressure and boiling point in liquids is

	Intermolecular Forces	Vapour Pressure	Boiling Point
A	strong	low	low
B	strong	high	high
C	weak	low	high
D	weak	high	low

25. The molecular formula of both rhombic and monoclinic sulphur is
- S_2
 - S_4
 - S_6
 - S_8
26. Which of the following statements stands TRUE for the formation of lithium chloride?

(Note: ${}^7_3\text{Li}$ and ${}^{35.5}_{17}\text{Cl}$)

- A lithium atom gives an electron to the chlorine atom.
 - A chlorine atom gives an electron to the lithium atom.
 - A chlorine atom shares an electron with the lithium atom.
 - A lithium atom accepts a pair of electrons from the chlorine atom.
27. Covalent compounds do not conduct electricity because they
- are highly volatile in nature.
 - lack the ability to form ions.
 - readily decompose into elements.
 - have relatively low melting point.
28. Which of the following properties is TRUE for ionic compounds?
- They are malleable and ductile.
 - They have low melting and boiling points.
 - They are brittle and dissolve easily in organic solvents.
 - They dissolve in polar solvents and conduct electricity in molten form.
29. In the given molecule, bonds **I** and **II** are identified as

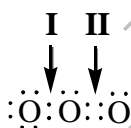

	I	II
A	Ionic bond	Ionic bond
B	Single covalent bond	Coordinate covalent bond
C	Single covalent bond	Double covalent bond
D	Coordinate covalent bond	Double covalent bond

PLEASE TURN OVER THE PAGE

30. Given are the attributes of a bond.

- It facilitates the formation of an alloy.
- It results in the conduction of electric current.
- It exists between nucleus and electrons of atoms of the same element.

The type of bond is

- A. ionic.
- B. dative.
- C. metallic.
- D. covalent.

31. The term, 'oxidation' of a substance means

- A. gain of electron and loss of oxygen atom.
- B. gain of oxygen atom and loss of electron.
- C. gain of electron and loss of hydrogen atom.
- D. gain of hydrogen atom and loss of electron.

32. To prevent underground iron pipes from rapid corrosion, blocks of metal **X** are buried close to the pipes and connected by wires. This is called sacrificial protection.

The metal **X** is

- A. lead.
- B. gold.
- C. silver.
- D. magnesium.

33. Ebrahim observes that the bulb connected to an electrolytic cell does not glow when ethanol is placed in the cell. He infers ethanol to be a non-electrolyte because it

- A. is highly volatile in nature.
- B. stays as molecules in a solution.
- C. has relatively low melting point.
- D. becomes solvated by water molecules.

34. During the electrolysis of brine (concentrated solution of sodium chloride and water), the substance that is produced at the anode is

- A. H_2
- B. Na
- C. Cl_2
- D. H_2O

35. In the presence of oxygen and moisture from the air, iron corrodes and forms

- A. iron oxide.
- B. iron nitrate.
- C. iron chloride.
- D. iron sulphate.

36. Which of the following statements is FALSE for soft metals?
- A. They are easy to break.
 - B. They have low binding energies.
 - C. They belong to d-block of the periodic table.
 - D. They have less delocalised electrons than hard metals.
37. Phosphorus depicts all of the following characteristics EXCEPT that it can exist
- A. in several allotropic forms.
 - B. as a multivalent non-metal.
 - C. as a free element on the Earth.
 - D. as a waxy and colourless solid.
38. The characteristic of non-metals that contributes to their inability to conduct heat effectively is
- A. low density.
 - B. high melting point.
 - C. lack of free electrons.
 - D. high thermal expansion.
39. What happens when a piece of calcium metal is added to water?
- A. It gives double displacement reaction with water.
 - B. It floats on the surface and does not react with water.
 - C. It forms calcium oxide with a characteristic orange flame.
 - D. It produces calcium hydroxide and liberates hydrogen gas.
40. Which of the following displacement reactions can occur based on the oxidising power of halogens?
- A. $F_2 + 2KI \rightarrow I_2 + 2KF$
 - B. $I_2 + 2KCl \rightarrow Cl_2 + 2KI$
 - C. $Br_2 + 2KF \rightarrow F_2 + 2KBr$
 - D. $Br_2 + 2KCl \rightarrow Cl_2 + 2KBr$

END OF PAPER

AGA KHAN UNIVERSITY EXAMINATION BOARD

SECONDARY SCHOOL CERTIFICATE

CLASS IX

MODEL EXAMINATION PAPER 2026 AND ONWARDS

Chemistry Paper I

Time: 1 hour 10 minutes Marks: 40

INSTRUCTIONS:

1. Check your name and school information on the question paper and Optical Mark Recognition (OMR) sheet. Sign on both if the information is correct.
2. Read each question carefully.
3. Answer all questions on the provided OMR sheet within the allotted time. DO NOT mark your answers on the question paper.
4. There are 100 answer numbers on the OMR sheet. Use answer numbers 1 to 40 only.
5. Each question has four choices: A, B, C, and D. Choose ONE correct answer only. On the OMR sheet, completely fill in the circle corresponding to your choice with a pencil as shown in the example below.

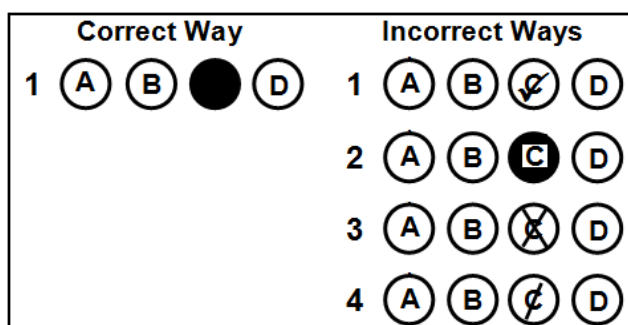

Candidate's Signature

6. If you want to change your answer, ERASE the first answer completely with an eraser, before filling in the new circle. Ensure your marks are dark and clear. Do not make stray marks or leave incomplete fillings as the OMR machine ONLY records what is in the circles.
7. Do not fold, tear, or damage the OMR sheet. Damaged sheets may be scanned incorrectly.
8. You may use a simple calculator if you wish.

1. The valency of iron (Fe) in $\text{Fe}(\text{NO}_3)_3$ is
 - A. 0
 - B. +1
 - C. +2
 - D. +3
2. For a research project, a student investigates the presence of minerals, including their occurrence, chemical composition and changes over time.

This study relates to the field of

- A. biochemistry.
 - B. geochemistry.
 - C. organic chemistry.
 - D. polymer chemistry.
3. $\text{H}_3\text{C}^\bullet$ is a free radical because it
 - A. is a stable unit.
 - B. carries a net charge.
 - C. possesses odd number of electrons.
 - D. forms in the absence of light energy.
 4. Consider the given features.
 - Purest form of substance
 - Possesses only one type of atom
 - Exists in bonded or non-bonded forms

The substance that exhibits all these features is a/ an

 - A. radical.
 - B. mixture.
 - C. element.
 - D. compound.
 5. Analytical chemistry is the branch of chemistry that deals with the techniques required for
 - A. naming different substances.
 - B. separating and identifying substances.
 - C. reacting organic and inorganic compounds.
 - D. changing the physical structure of compounds.

6. A soft drink contains 0.5 moles of carbon dioxide (CO₂) dissolved in it. How many CO₂ molecules are present in the drink?

(Note: $^{12}_6\text{C}$ and $^{16}_8\text{O}$)

- A. 3.01×10^{23} molecules
 B. 6.02×10^{23} molecules
 C. 1.50×10^{24} molecules
 D. 3.01×10^{24} molecules
7. $w\text{NH}_{3(g)} + x\text{O}_{2(g)} \rightarrow y\text{NO}_{(g)} + 6\text{H}_2\text{O}_{(g)}$

To balance the given chemical equation, the values of **w**, **x** and **y** would be

	w	x	y
A	2	5	2
B	2	3	2
C	4	5	4
D	4	3	4

8. A compound **X** has an empirical formula C₄H₉ and its molecular mass is 114 g/mol.

Based on the given information, the molecular formula of compound **X** will be

(Note: $^{12}_6\text{C}$ and ^1_1H)

- A. C₆H₁₁
 B. C₇H₁₂
 C. C₈H₁₈
 D. C₁₂H₂₇
9. A student adds a piece of zinc metal to hydrochloric acid in a test tube and records the following observations:
- I. The zinc becomes smaller in size.
 II. The solution remains colourless.
 III. A gas is released with bubbling.
 IV. The reaction vessel feels warm.

Which combination of observations definitely proves a chemical reaction has occurred?

- A. I and II
 B. I and III
 C. II and IV
 D. III and IV

PLEASE TURN OVER THE PAGE

10. The percentage by mass of sulphur (S) in one molecule of sodium thiosulphate ($\text{Na}_2\text{S}_2\text{O}_3$) is

(Note: ${}^{23}_{11}\text{Na}$, ${}^{16}_8\text{O}$ and ${}^{32}_{16}\text{S}$)

- A. 32.85%.
- B. 40.51%.
- C. 70.01%.
- D. 91.43%.

11. In a molecule of ethyne (C_2H_2), how many electron pairs are involved in the bonding between carbon-carbon atoms?

- A. 2
- B. 3
- C. 4
- D. 5

12. Read the given characteristics.

- Usually dissolves in water
- Carries partial charges on atoms
- Uneven distribution of electrons

Based on the given characteristics, an example of polar covalent molecule is

- A. O_2
- B. Cl_2
- C. H_2S
- D. NaCl

13. $\left[\begin{array}{c} \bullet\bullet \\ \bullet\text{Cl}\times \\ \bullet\bullet \end{array} \right]^- \left[\text{Mg} \right]^{2+} \left[\begin{array}{c} \bullet\bullet \\ \times\text{Cl}\bullet\bullet \\ \bullet\bullet \end{array} \right]^-$
 (2,8,8) (2,8) (2,8,8)

The given dot and cross structure exemplifies the formation of

- A. ionic bonds.
- B. metallic bonds.
- C. covalent bonds.
- D. coordinate covalent bonds.

14. Metals are good conductors of electricity due to the presence of

- A. freely moving electrons.
- B. number of positive charges on the ions.
- C. atoms in the form of rows one above the other.
- D. electrostatic forces of attraction between oppositely charged ions.

15. Two atoms, **X** and **Y**, have electronegativity values of 1.0 and 3.5, respectively.

The type of bond that will form between **X** and **Y** is

- A. ionic bond.
 B. metallic bond.
 C. polar covalent bond.
 D. non-polar covalent bond.
16. The isotope that is CORRECTLY matched with its application is

	Isotope	Application
A	Uranium-235	used in nuclear reactors for power generation
B	Iodine-131	used in industries as a fuel source
C	Technetium-99	used in determining the age of fossils
D	Sodium-24	used in nuclear weapons for energy release

17. Which of the following options shows the sub-atomic particles of a species having a +1 charge on it?

	Number of Electrons	Number of Protons	Number of Neutrons
A	18	20	20
B	18	19	20
C	10	9	10
D	10	8	8

18. Rutherford's atomic model explains all of the following statements EXCEPT that the

- A. volume occupied by the nucleus is very small.
 B. positively charged particles exist inside the nucleus.
 C. entire mass of the atom is concentrated in the nucleus.
 D. energy emitted by the electrons forms a line spectrum.
19. The electronic configuration of potassium (${}_{19}^{39}\text{K}$) is
- A. $1s^2, 2s^2, 2p^6, 3s^2, 3p^5$
 B. $1s^2, 2s^2, 2p^6, 3s^2, 3p^6$
 C. $1s^2, 2s^2, 2p^6, 3s^2, 3p^6, 4s^1$
 D. $1s^2, 2s^2, 2p^6, 3s^2, 3p^6, 4s^2$

PLEASE TURN OVER THE PAGE

20. How many sub-shells are present in an L-shell?

- A. 1
- B. 2
- C. 3
- D. 4

21. A transition metal has the following characteristics:

- Weak metallic bonds
- Low melting point

Based on these characteristics, the metal is identified as

- A. iron.
- B. copper.
- C. mercury.
- D. titanium.

22. In the periodic table, an element with atomic number 14 is placed in period

- A. 1
- B. 2
- C. 3
- D. 4

23. Which of the following statements is FALSE regarding ionisation energy of elements?

- A. The first ionisation energy of lithium is less than that of beryllium.
- B. The second ionisation energy of magnesium is less than that of sodium.
- C. It is the amount of energy required to remove an electron from a gaseous atom or ion.
- D. It is the tendency of an atom or molecule to attract electrons of other atom or molecule to itself.

24. If a solid substance conducts electricity, then it must be a/ an

- A. metal.
- B. non-metal.
- C. ionic compound.
- D. covalent compound.

25. Barium belongs to group IIA while chlorine belongs to group VIIA of the modern periodic table.

If barium reacts with chlorine, then their product is

- A. BaCl
- B. BaCl₂
- C. Ba₂Cl
- D. Ba₂Cl₂

26. The heating curve below shows the temperature of a solid substance as it is heated over time. At points **X** to **Y**, the temperature remains constant even though heat is continuously added.

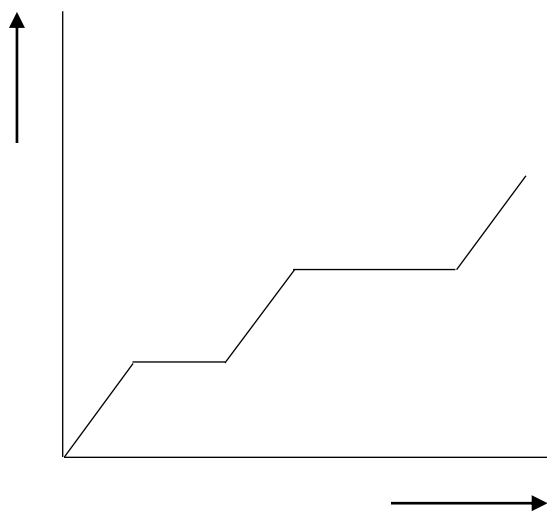

- Aligning with the kinetic theory of matter, this occurs because the added energy
- A. stops the transfer of heat to the substance.
 - B. increases the kinetic energy of particles.
 - C. overcomes intermolecular forces.
 - D. disables particles' movement.
27. At constant temperature and pressure, which of the following gas molecules will diffuse the fastest through air?
- (Note: Atomic mass of O = 16 amu, Cl = 35.5 amu, N = 14 amu, C = 12 amu and H = 1 amu)
- A. $O_{2(g)}$
 - B. $Cl_{2(g)}$
 - C. $NO_{2(g)}$
 - D. $CH_{4(g)}$
28. At constant temperature, if the volume of a gas in a container is reduced to half, then the pressure on the gas will
- A. be doubled.
 - B. reduce to half.
 - C. remain the same.
 - D. reduce to a quarter.

PLEASE TURN OVER THE PAGE

29. In the given diagrams, the rate of evaporation of water at room temperature, i.e., 25°C would be the greatest in

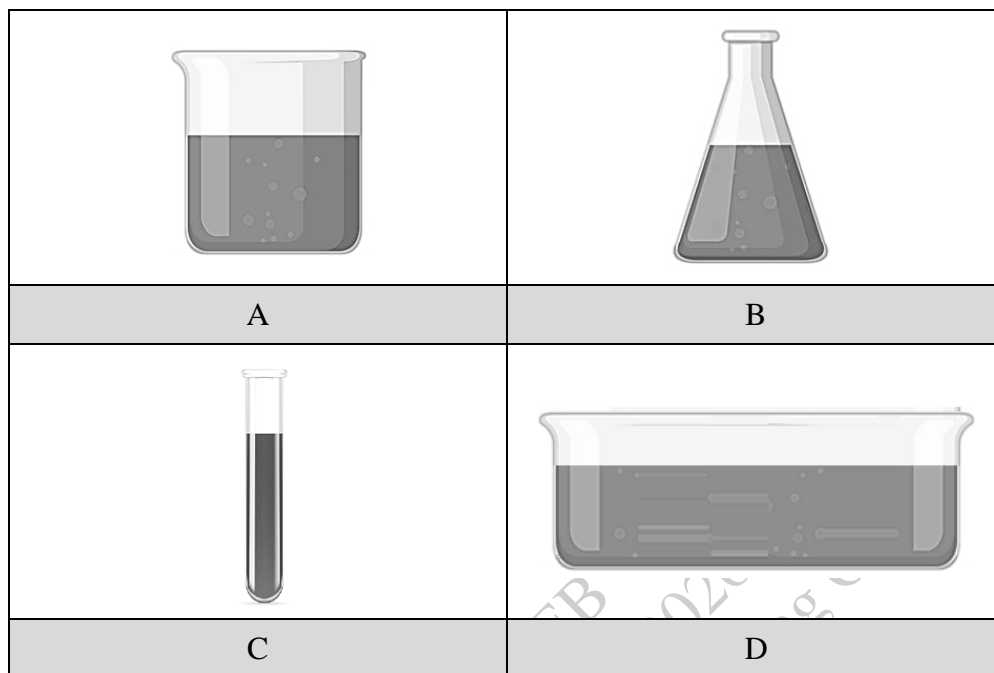

30. Ahmed plotted a graph representing Charles's Law. He placed temperature on **x-axis** and volume of one mole of an ideal gas on **y-axis**.

At a constant pressure, Ahmed obtained a straight line which intersects the **x-axis** at

- A. -273.16°C.
 B. -273.16 K.
 C. 0°C.
 D. 300 K.
31. What is the molarity of a solution containing 32 g of potassium sulphate (K_2SO_4) in 350 cm³ of solution?

(Note: Molar mass of $K_2SO_4 = 174 \text{ g mol}^{-1}$)

- A. 0.06 M
 B. 0.09 M
 C. 0.52 M
 D. 64.37 M

32. The given diagram shows an area covered in fog.



Fog is a solution of

- A. gas in liquid.
 B. liquid in gas.
 C. solid in liquid.
 D. liquid in liquid.
33. An INCORRECT difference between solution and suspension is

	Solution	Suspension
A	it passes through the filter paper.	it leaves residue on filtration.
B	it forms homogeneous mixture.	it forms heterogeneous mixture.
C	it does not show Tyndall effect.	it may show Tyndall effect.
D	it appears translucent.	it appears transparent.

34. A teacher asks a student to dissolve 2.5 g of sodium carbonate in 50 g of water. What will be the concentration of the prepared solution?
- A. 0.048 %
 B. 0.050 %
 C. 4.762 %
 D. 5.000 %
35. In a science laboratory, Mariam prepared a mixture of SiO_2 and $\text{K}_2\text{SO}_4 \cdot \text{Al}_2(\text{SO}_4)_3 \cdot 24\text{H}_2\text{O}$ in water. She then applied the process of filtration on the mixture.

An inference Mariam must have made through this experiment is that

- A. SiO_2 is insoluble in water.
 B. SiO_2 easily passes through the filter paper.
 C. $\text{K}_2\text{SO}_4 \cdot \text{Al}_2(\text{SO}_4)_3 \cdot 24\text{H}_2\text{O}$ is an amorphous solid.
 D. $\text{K}_2\text{SO}_4 \cdot \text{Al}_2(\text{SO}_4)_3 \cdot 24\text{H}_2\text{O}$ easily settles down in water.

PLEASE TURN OVER THE PAGE

36. Which of the following CORRECTLY matches the redox reaction with its inference?

	Redox Reaction	Inference
A	$2\text{HI}_{(g)} + \text{Cl}_{2(g)} \rightarrow \text{I}_{2(g)} + 2\text{HCl}_{(g)}$	Hydrogen iodide is reduced to iodine.
B	$\text{Mg}_{(s)} + 2\text{HCl}_{(aq)} \rightarrow \text{MgCl}_{2(aq)} + \text{H}_{2(g)}$	Magnesium is reduced to magnesium chloride.
C	$\text{CuSO}_{4(aq)} + \text{Mg}_{(s)} \rightarrow \text{MgSO}_{4(aq)} + \text{Cu}_{(s)}$	Copper sulphate is reduced to copper.
D	$\text{H}_2\text{S}_{(g)} + \text{Cl}_{2(g)} \rightarrow \text{S}_{(s)} + 2\text{HCl}_{(g)}$	Hydrogen sulphide is reduced to sulphur.

37. The gas(es) produced during the electrolysis of fused sodium chloride in Down's cell is/ are

- I. $\text{Cl}_{2(g)}$
- II. $\text{O}_{2(g)}$
- III. $\text{H}_{2(g)}$

- A. I only.
- B. III only.
- C. I and II.
- D. I and III.

38. When Altamash places iron nails in a copper sulphate solution, the solution's colour changes from blue to light green.

What does this observation indicate about the reaction?

- A. The melting of iron nails in the solution
- B. The formation of iron sulphate in the solution
- C. The dissolution of metallic copper in the solution
- D. The corrosion of iron nails in copper sulphate solution

39. A solution of 1.0 M sodium chloride conducts electricity well, while a 1.0 M sugar solution does not.

Based on the difference in electrical conductivities of the two given solutions, it can be inferred that

- A. sodium chloride absorbs more water, increasing its conductivity.
- B. sugar has larger molecules, making it harder to conduct electricity.
- C. sodium chloride dissociates into ions, but sugar remains as discrete molecules.
- D. both solutions have same concentrations, but sugar has a higher molecular mass.

40. Consider the given galvanic cell.

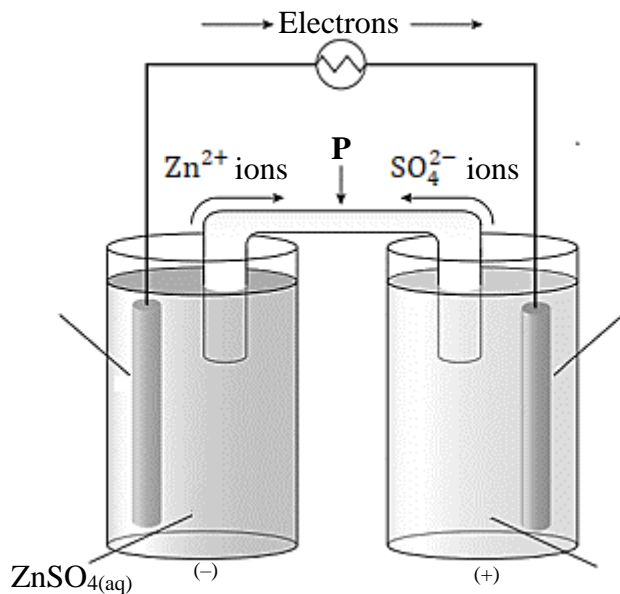

The component **P** is identified as a/an

- A. battery.
- B. ammeter.
- C. voltmeter.
- D. salt bridge.